



Designer C990H

USER MANUAL



Designer C990H V1.0 2021-09

Exploded View

分解圖 | 分解图 | 分解図 | 분해도 | Vista Esplosa | Vue Éclatée | В разобранном виде | Explosionszeichnung | Sprängskiss/Widok rozstrzelony | patlatılmış görünüm | Diagrama de decomposição | Vista en despiece ordenado | Rozložený pohled

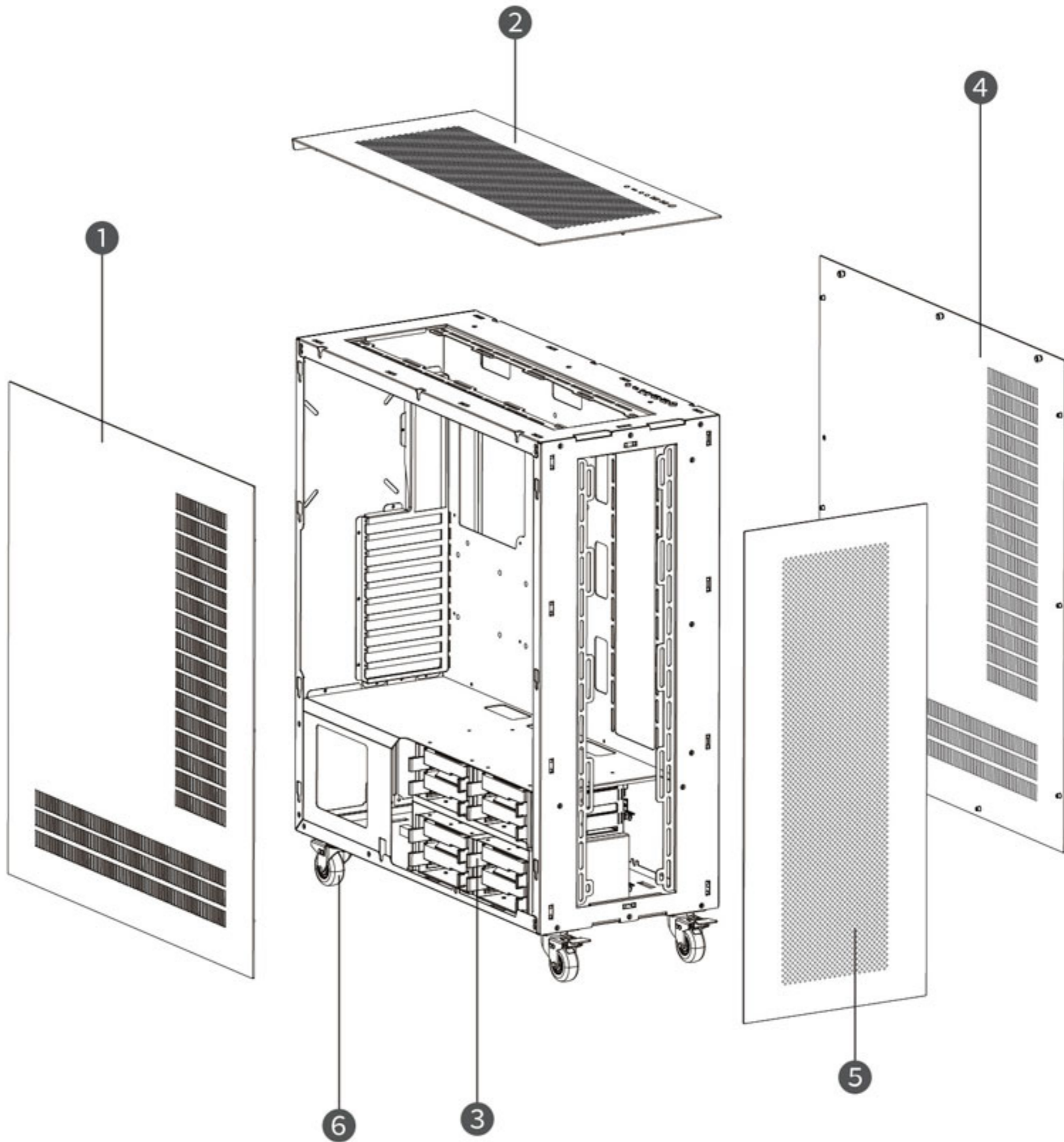

①	Left Side Panel	②	Top Cover	③	HDD/SSD Drive Bracket
④	Right Side Panel	⑤	Front Panel	⑥	Universal Wheel

Specifications

規格 | 规格 | 規格 | 사양 | Specifiche | Spécifications | Спецификация | Spezifikation |
Tekniskdata | specyfikacja | Spesifik | Especificação | Especificaciones | Specifikace

Model		abee Designer C990H
Material	Frame & Exterior Parts	Aluminum, SPCC, ABS
	Panels	Aluminum
Dimension (L x W x H)	w wheels	685 x 260 x 582mm / 26.97 x 10.24 x 22.91 inch
	w/o wheels	625 x 260 x 582mm / 24.61 x 10.24 x 22.91 inch
Size		94.57L
Motherboard Compatibility		ETAX, XL-ATX, ATX (Max. up to 345 x 340mm)
Expansion Slots		10
Drive Bays	3.5"/2.5" Drive (Combo)	11
Front I/O Ports		1 x USB 3.2 Gen 1 (Type C) / 2 x USB 3.0 2 x 3.5mm Headset Jack (In/Out)
Cooling Support	Top	4 x 120mm or 3 x 140mm
	Front	4 x 120mm or 4 x 140mm
	Rear	1 x 120mm or 1 x 140mm
	Side	3 x 120mm
Radiator Compatibility	Top	1 x 480mm (Thickness: up to 45mm)
	Front	1 x 360mm (Thickness: up to 45mm)
	Side	1 x 360mm (Thickness: up to 45mm)
	Rear	1 x 140mm (Thickness: up to 45mm)
Maximum CPU Cooler Height		Max. up to 194mm
Maximum GPU Length		Max. up to 390mm
Maximum PSU Length		Support Dual ATX PSU Installation Max. up to 210mm
*Product specifications might vary by country or region.		





Front I/O Ports

I/O接口 | I/O接口 | I/O인터페이스 | I/O인터페이스 | I/O berlo | Porte I/O Anteriori |
Интерфейс ввода / вывода | I/O-Schnittstelle | I/O-gränssnitt | I/O berlo |
Portos de E/S frontais | Puertos de I / S Frontales | I/O rozhraní

1	Power Button	2	USB 3.0	3	HD Audio (Headphone)
4	HD Audio (Microphone)	5	USB3.1 TYPE-C	6	Reset Button

Accessory Kit 1 Content

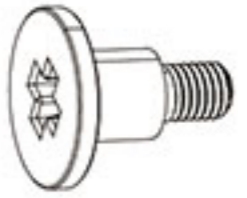
配件盒1内容 | 配件盒1内容 | アクセサリーボックス 1コンテンツ | 부품 케이스 1 내용 |
 Contenuto della Scatola degli Accessori 1 | Contenu de la Boîte d'Accessoires 1 |
 Содержимое коробки для принадлежностей 1 | Inhalt in der Zubehörbox 1 |
 Innehållet i Tillbehörslåda 1 | Zawartość w pudełku 1 akcesoriów |
 Aksesuar Kiti 1 İçeriği | Caixa de acessórios 1 | Contenido de la Caja de Accesorios 1 |
 Obsah krabice na příslušenství 1

Model	Name	QTY
	A Power Supply Unit Screws	8
	B Motherboard / 2.5" SSD Drive Tray Screws	41
	C 3.5" HDD Drive Bracket Screws	12
	D 2.5" SSD Drive Bracket Screws	12
	E 3.5" HDD Drive Tray Screws	16
	F PCB Board Isolation Column	10

Installation Guide

安裝指南 | 安裝指南 | インストールガイド | 설치 설명서 | Guida all'installazione |
 Guide d'installation | Руководство по установке | Installationsanleitung |
 Installationsguide | Instrukcja instalacji | Kurulum Kılavuzu | Manual de instalação |
 Guía de instalación | Instalační příručka

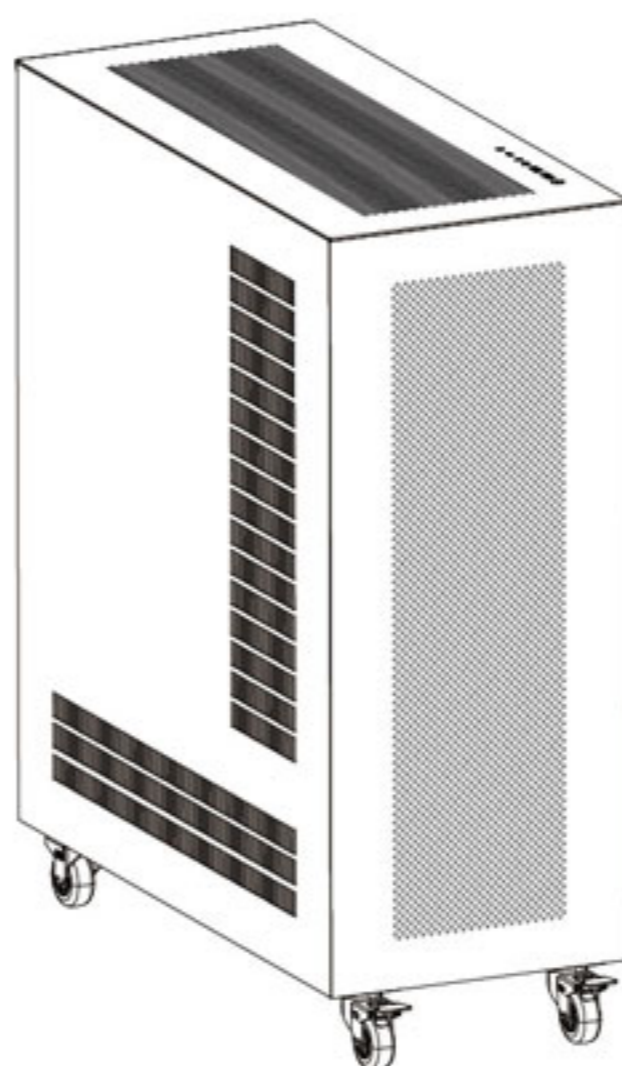

Remove The Top Cover

移除上蓋 | 移除上盖 | トップカバーの撤去 | 상부 커버 제거 |
 Rimuovere il coperchio superiore | Retirez le couvercle supérieur |
 Снимаем верхнюю крышку | Entfernen der obere Abdeckung | Avmontera toppen. |
 Zdejmij górną pokrywę | Üst kapağı çıkarın | Remover a tampa superior |
 Retire la cubierta superior | Sejměte horní kryt

1.

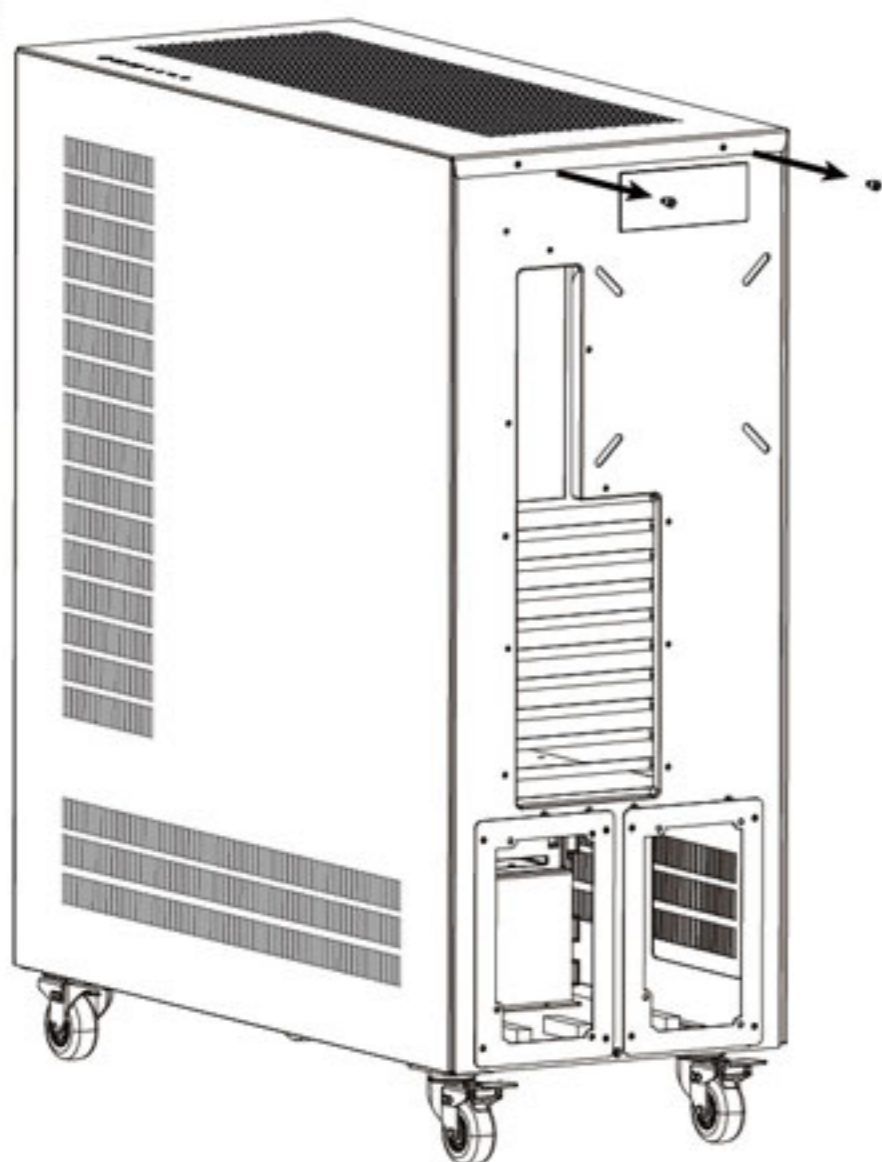

2.

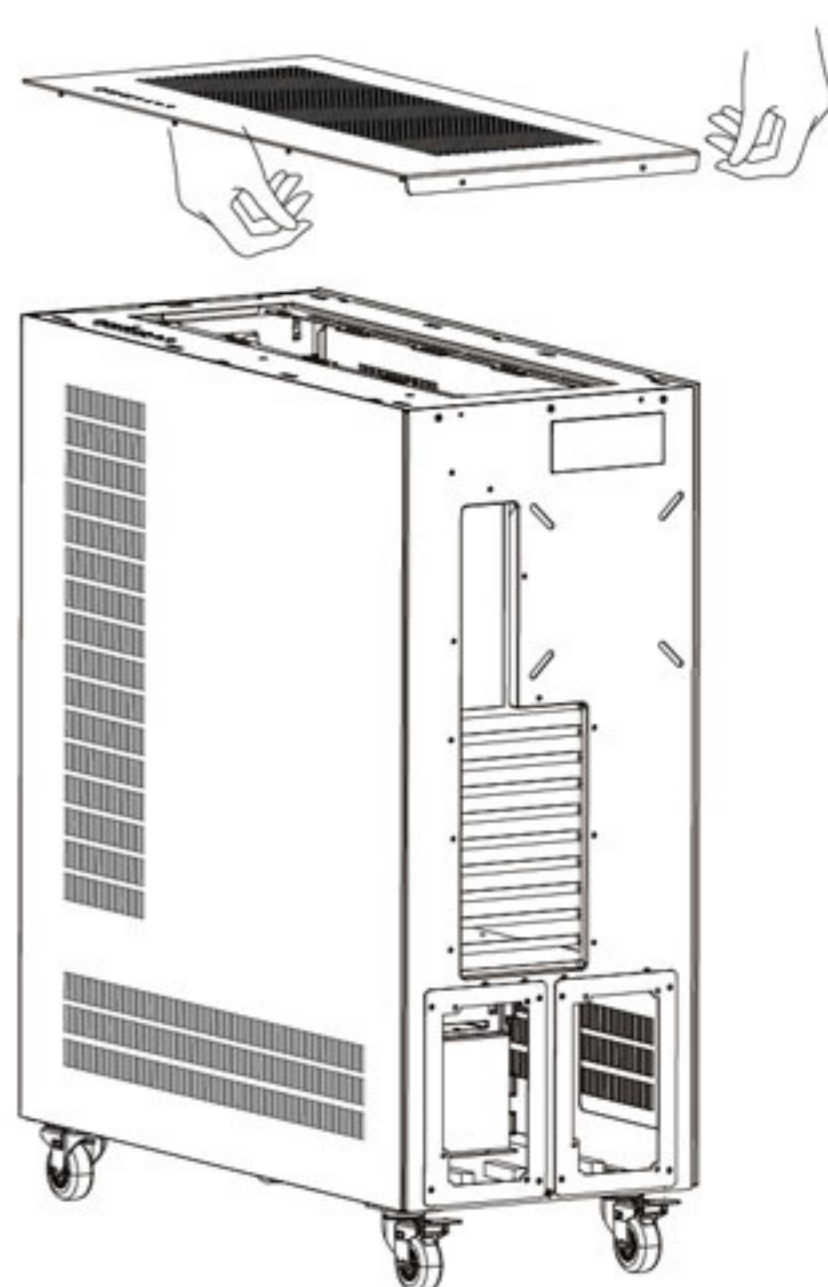

Remove Side Panels

移除側板 | 移除側板 | サイドプレートの撤去 | 측면 패널 제거 | Rimuovete i pannelli laterali |
 Retirer les panneaux latéraux | СНИМИТЕ боковые панели | Entfernen der Seitenwände |
 Ta bort sidopanelerna | Zdejmij panele boczne | Yan Panelleri Çıkarın |
 Remover os painéis laterais | Quite los paneles laterales | Sejměte boční panely

1.

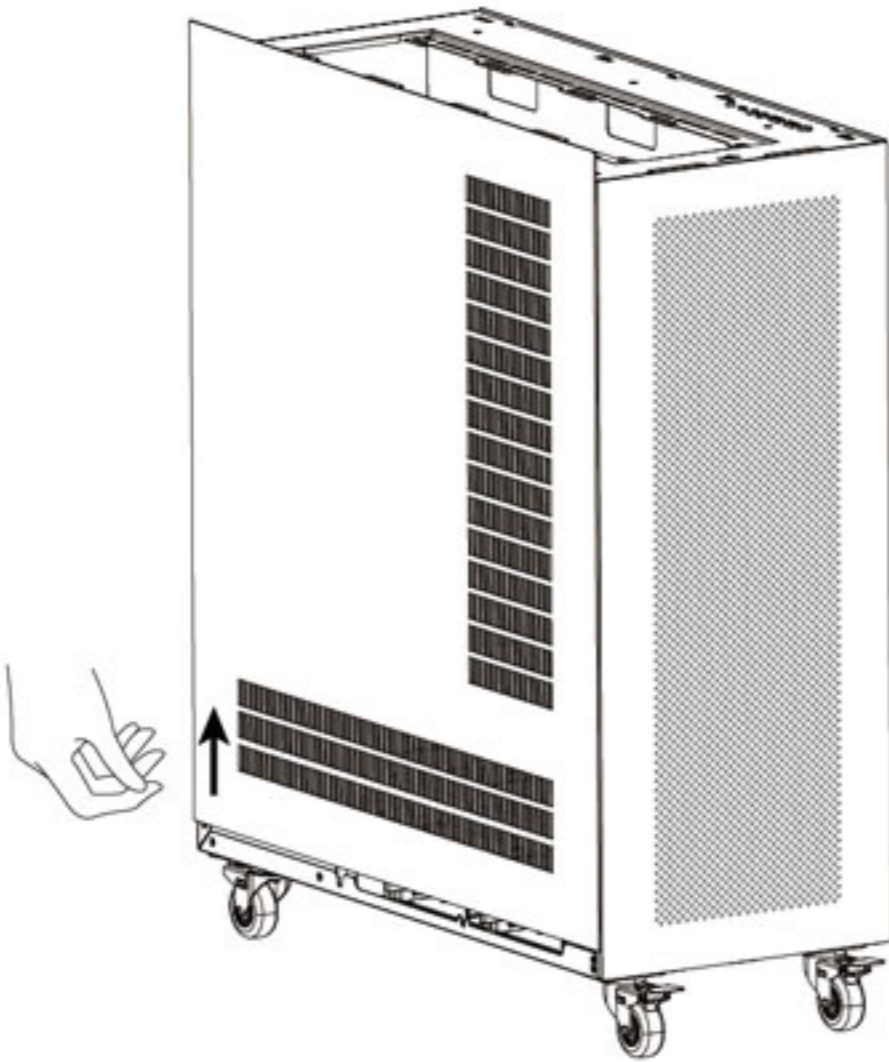

2.

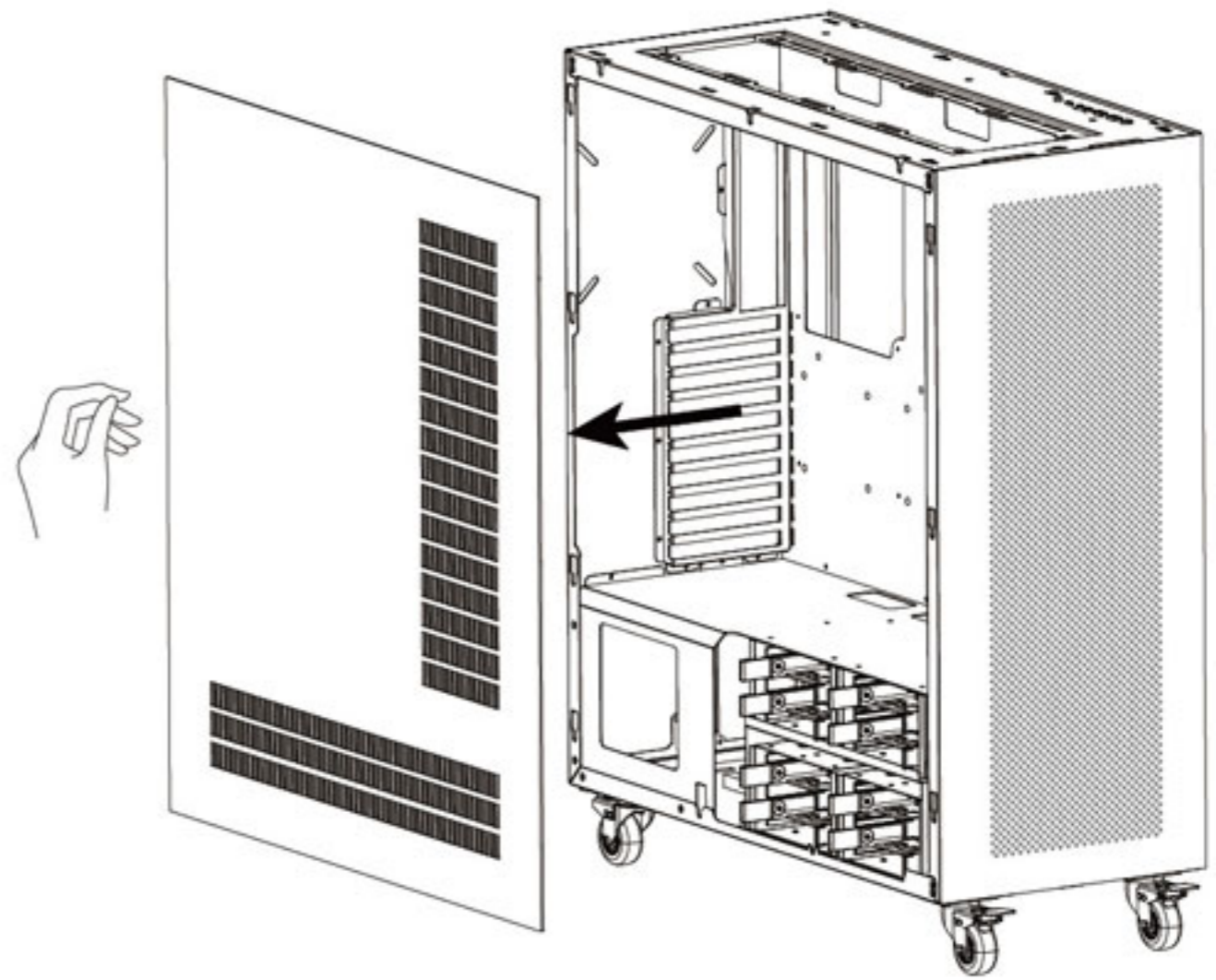

1.

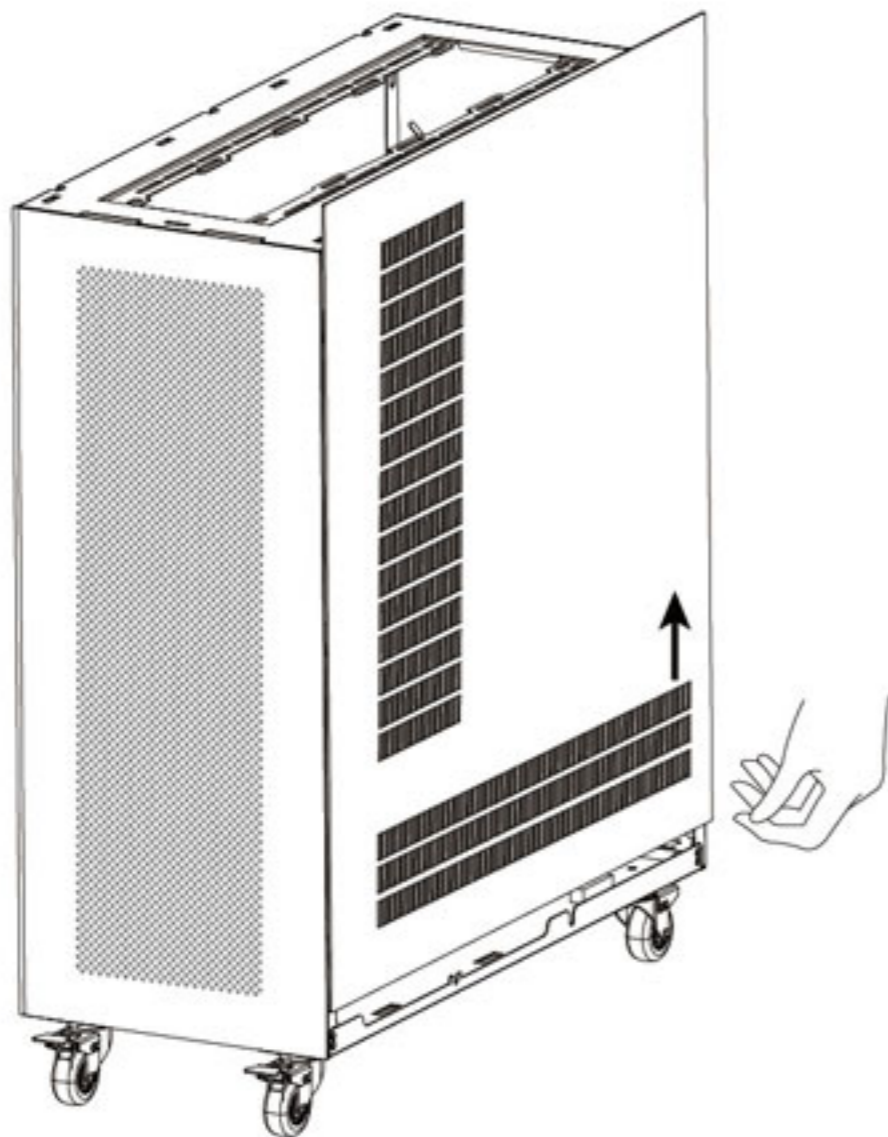

2.

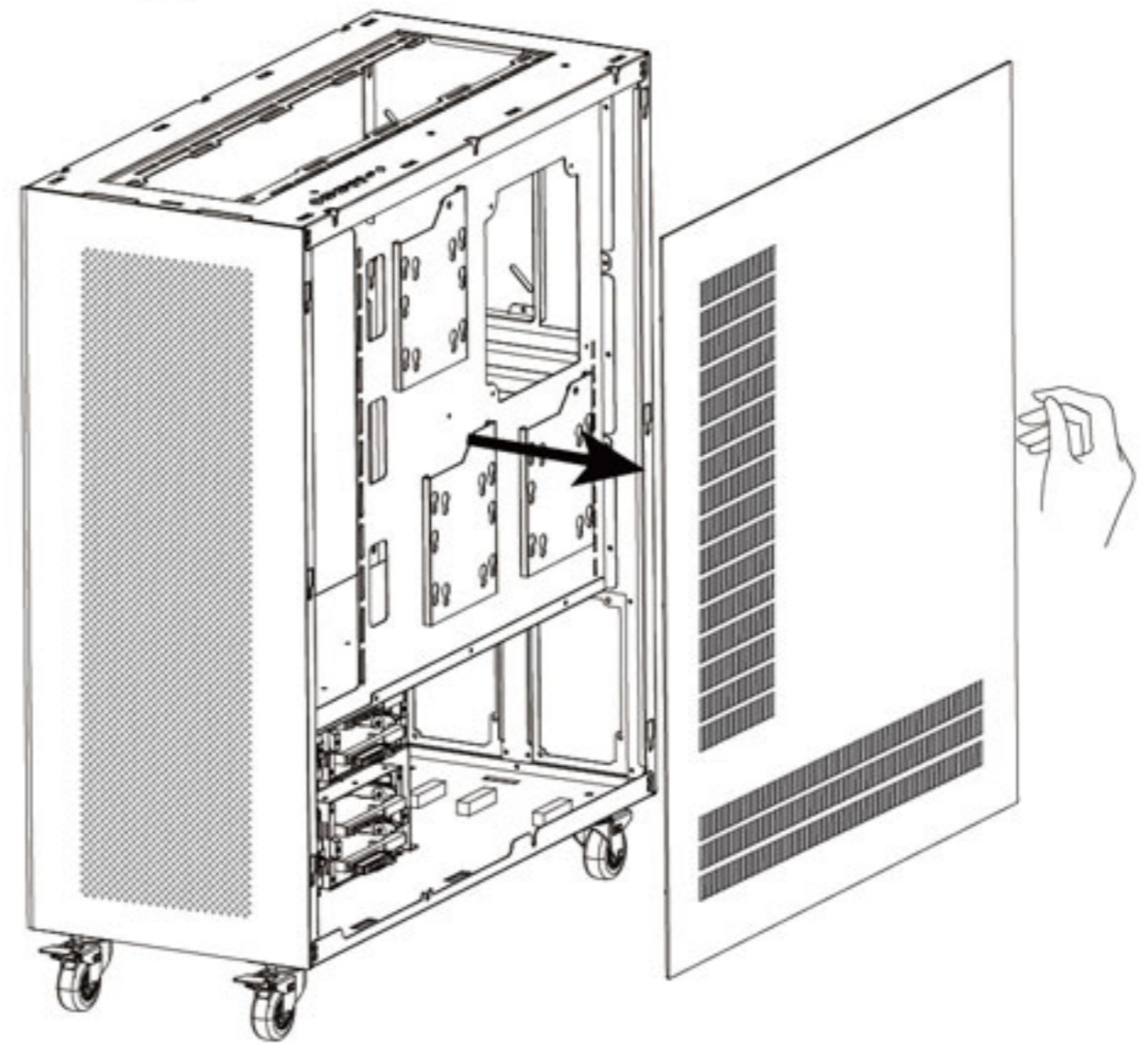

Remove The Front Panel

移除前面板 | 移除前板 | フロントパネルの撤去 | 전면 패널 제거 |
 Rimuovere il pannello frontale | Retirez le panneau avant |
 Снимаем переднюю пластину | Entfernen der Vorderplatte |
 Avmontera frampaneln | Zdejmij panel przedni | Ön paneli çıkarın |
 Remover o painel frontal | Retire el panel frontal | Sejměte přední panel

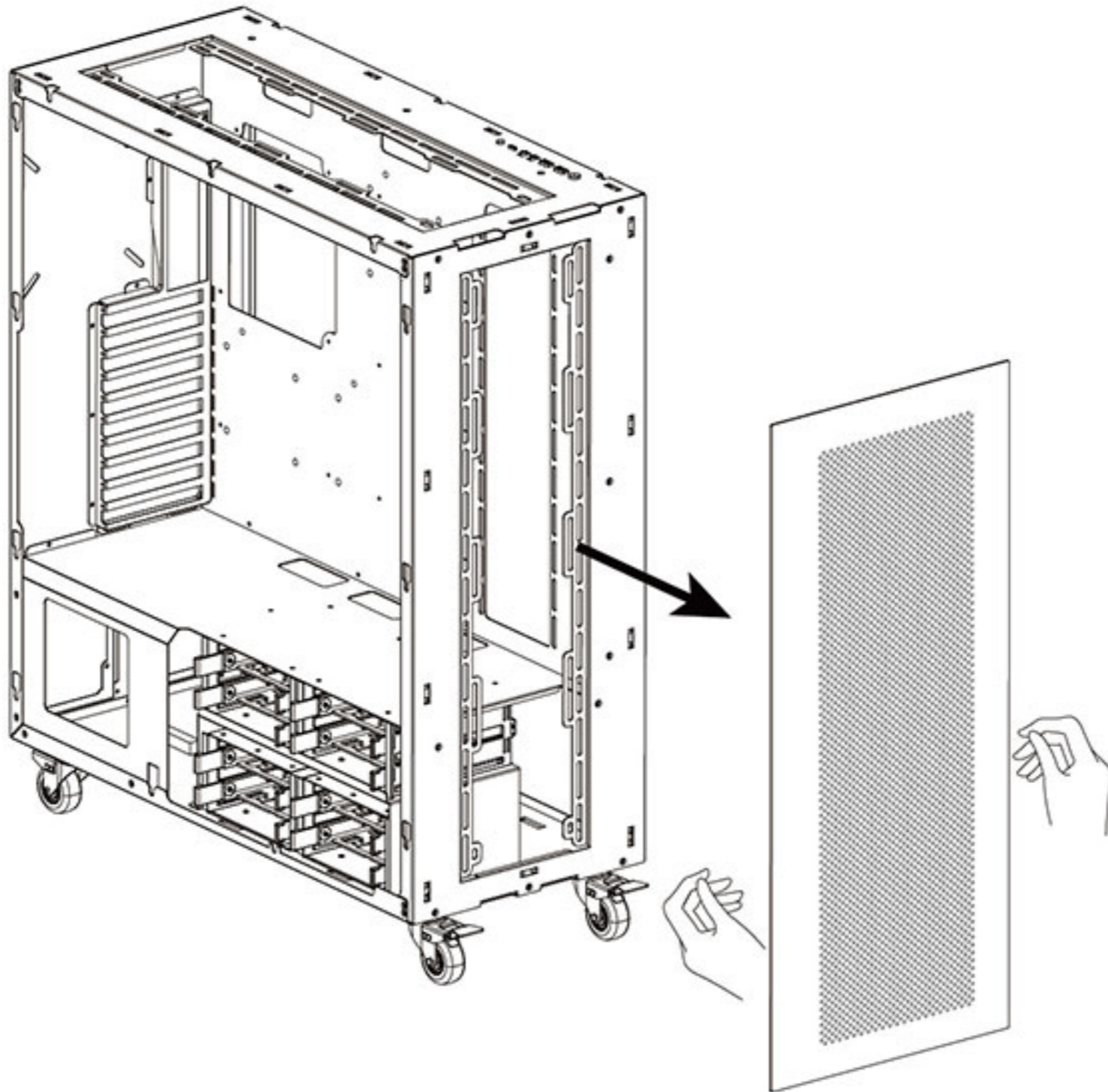

Install the I/O Shield & Motherboard Unit

將I/O擋板&主機板裝入機箱 | 將I/O擋板&主板裝入机箱 |

I/Oシールド&マザーボードユニットの取り付け | I/O 실드&머더보드 설치 |

Installare lo schermo I/O e l'unità della scheda madre |

Installez le bouclier d'E/S et l'unité de carte mère | Установите I/O перегородку и

материнскую плату в корпус. | Einlegen des I/O-Blechs und der Hauptplatine in die

Gehäuse | Placera I/O shield og moderkort enheten i chassit |

Zainstaluj przegrodę we/wy i płytę główną w obudowie |

I/O bölmelerini ve anakartları kasaya yerleştirin |

Instale a unidade de I/O Shield & Motherboard | Instale el protector de E / S y la unidad de

placa base | Nainstalujte přepážku I / O a základní desku do podvozku

1.

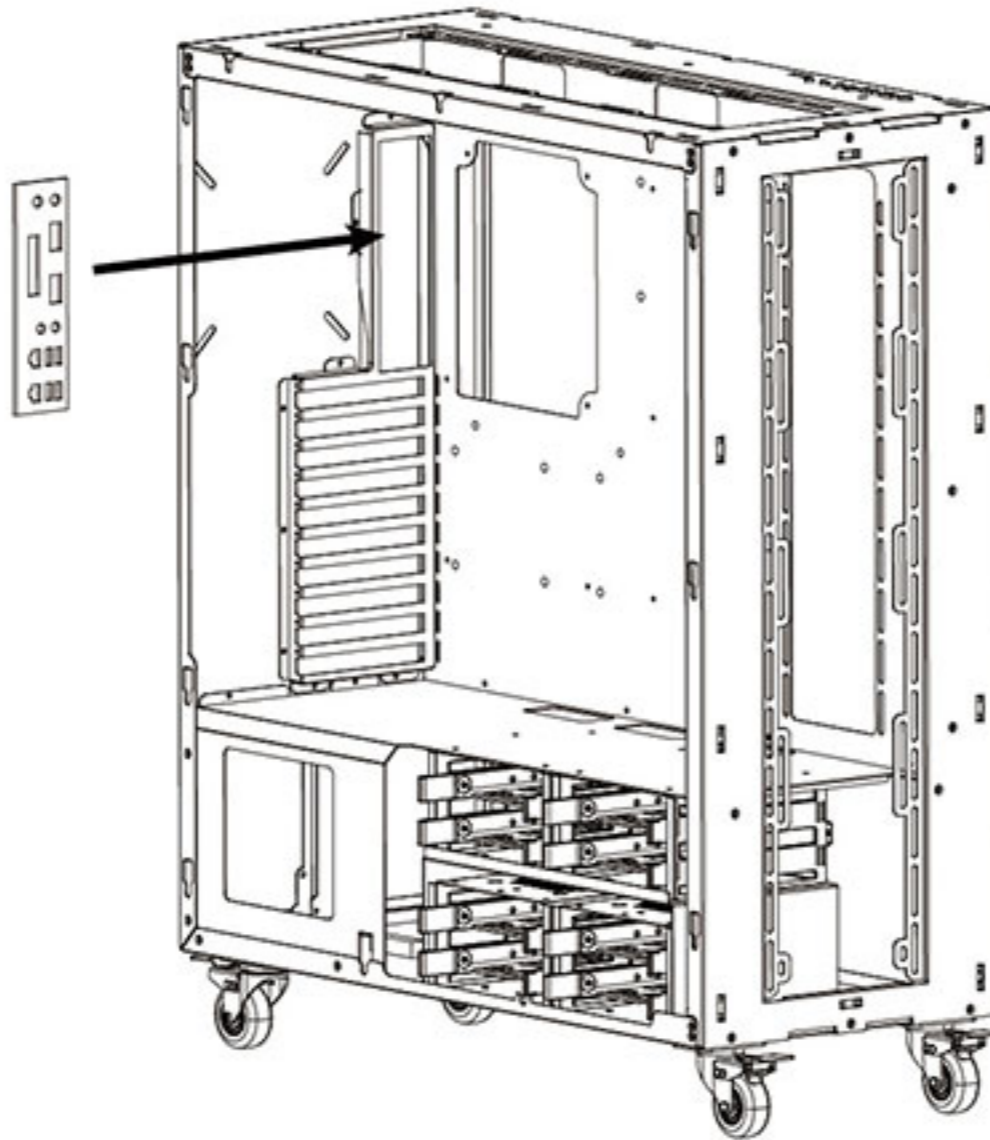

2. **B**  x 8

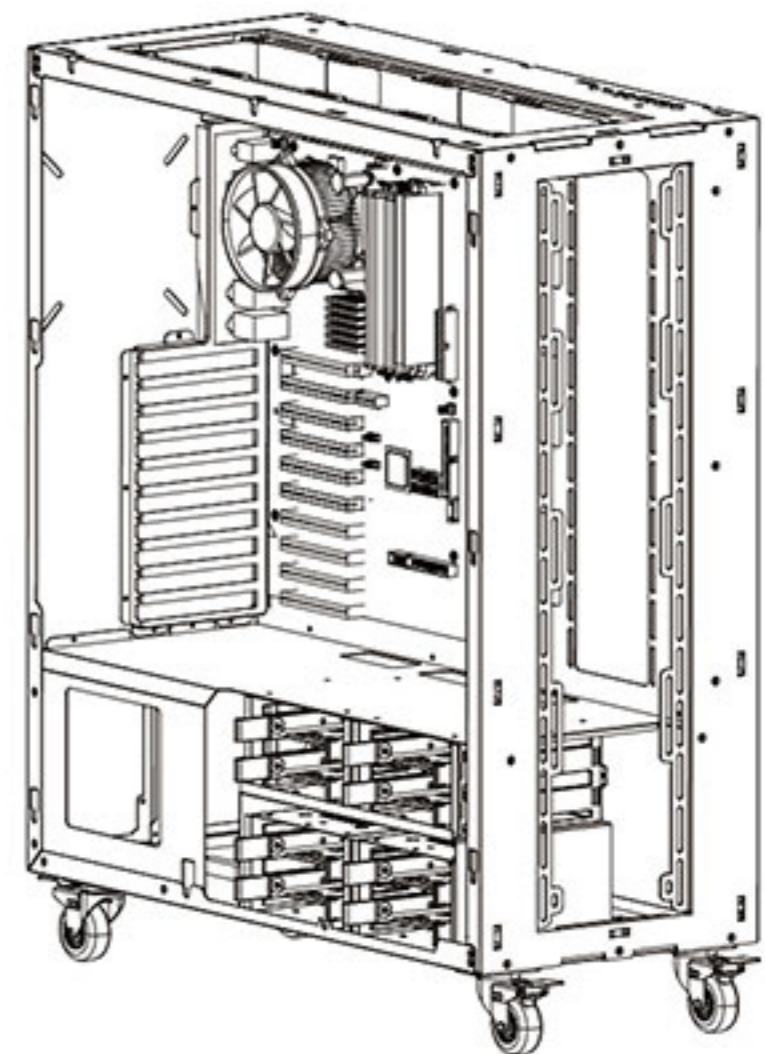
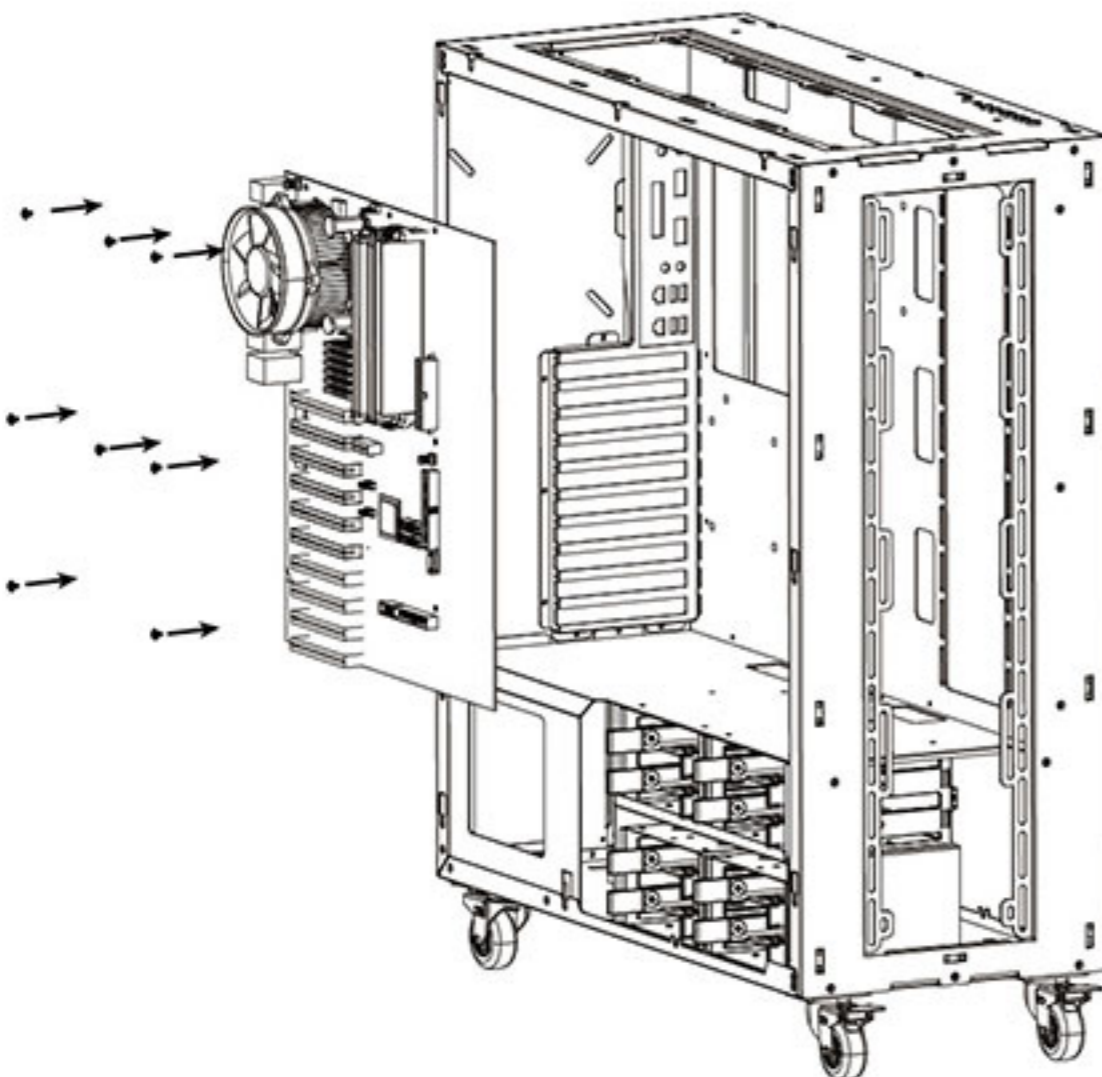

Install the PCI-E Card

安裝PCI-E卡 | 安裝PCI-E卡 | PCI-Eカードの取り付け | PCI-E 카드 설치 |
 Installate la scheda PCI-E | Installer la carte PCI-E | Установите карту PCI-E |
 Installation der PCI-E-Karte | Installera PCI-E-kortet | Zainstaluj kartę PCI-E |
 PCI-E Kartını Takın | Instalar a placa PCI-E | Instalar la tarjeta PCI-E |
 Nainstalujte PCI-E kartu

1.

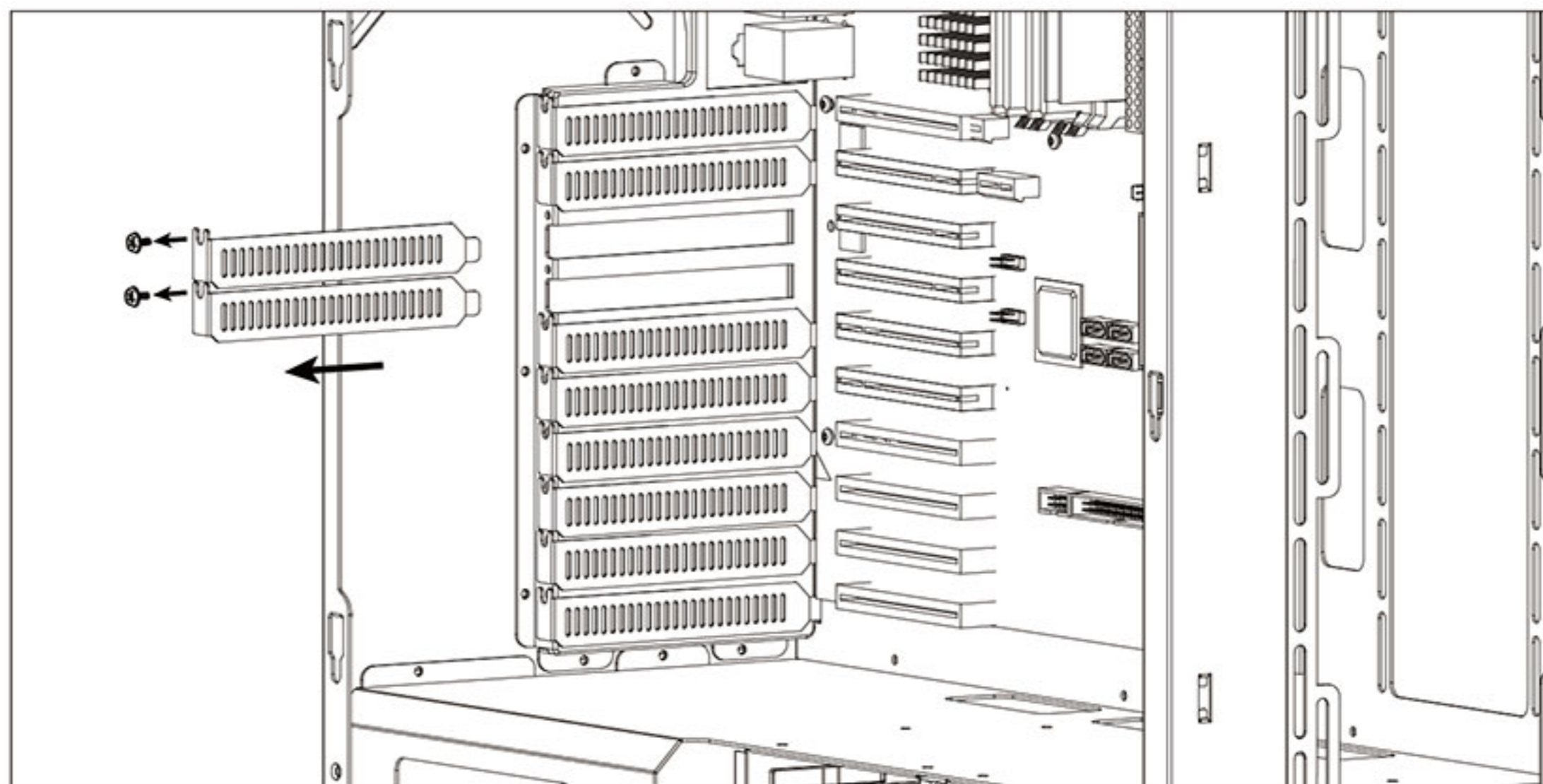

2.

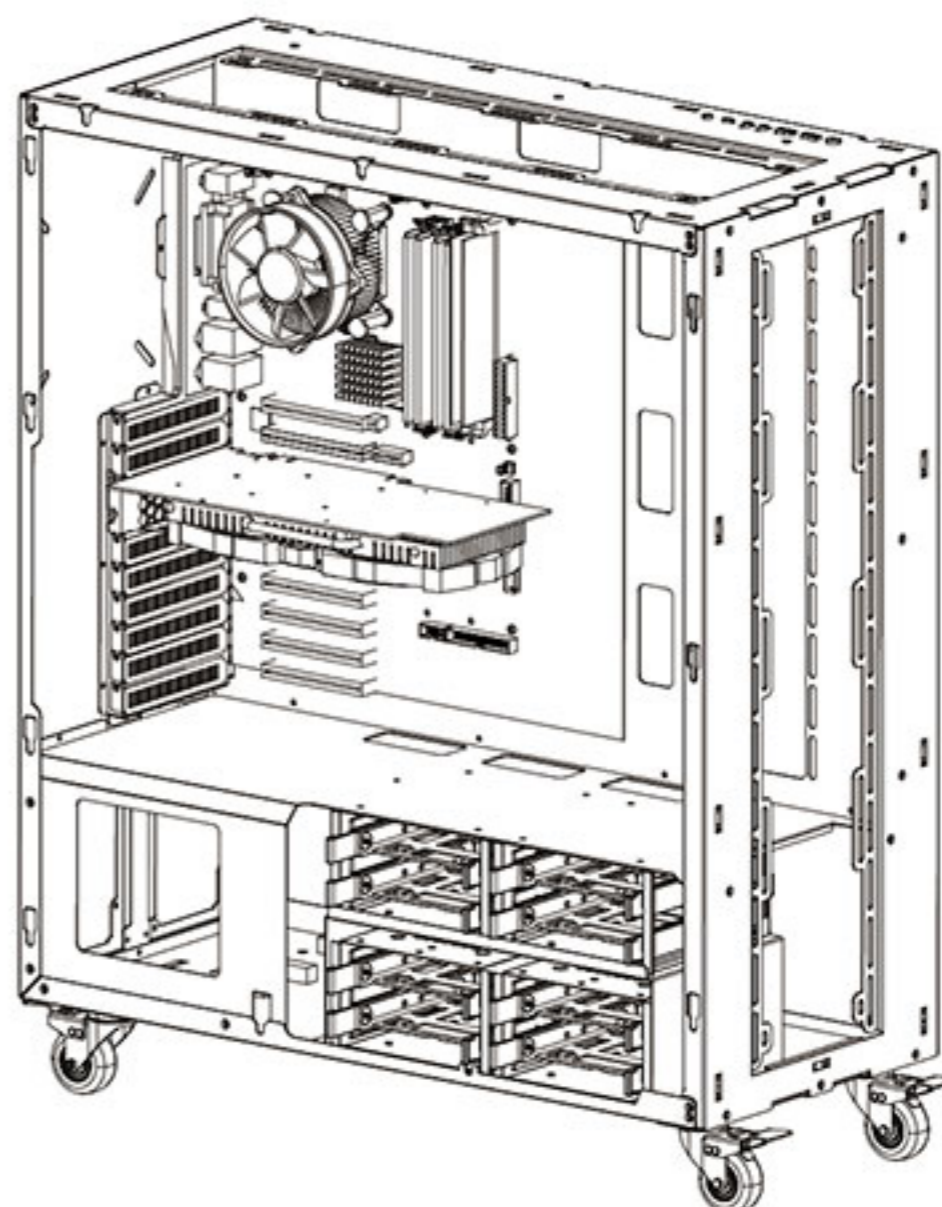
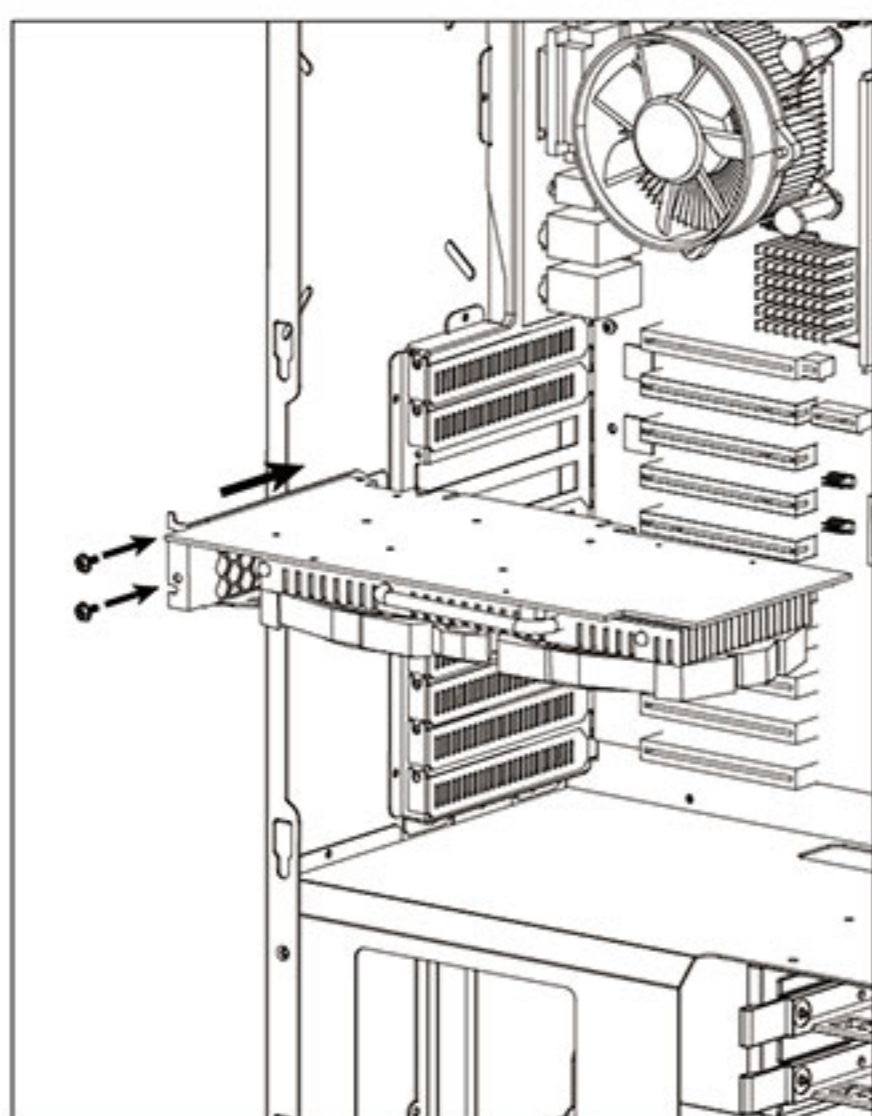

Install the Power Supply Unit (PSU)

安裝電源供應器 | 安装电源供应器 | パワーサプライの取り付け | 전원 공급장치(PSU) 설치 |
 Installate l'alimentatore (PSU) | Installer le bloc d'alimentation |
 Установите блок питания | Installation des Netzteils |
 Sätt i strömförsörjningsenheten (PSU) | Zainstaluj zasilacz (PSU) |
 Güç Kaynağı Ünitesini (PSU) Takın | Instalar a fonte de alimentação (PSU) |
 Instalar la fuente de alimentación (PSU) | Nainstalujte zdroj napájení (PSU)

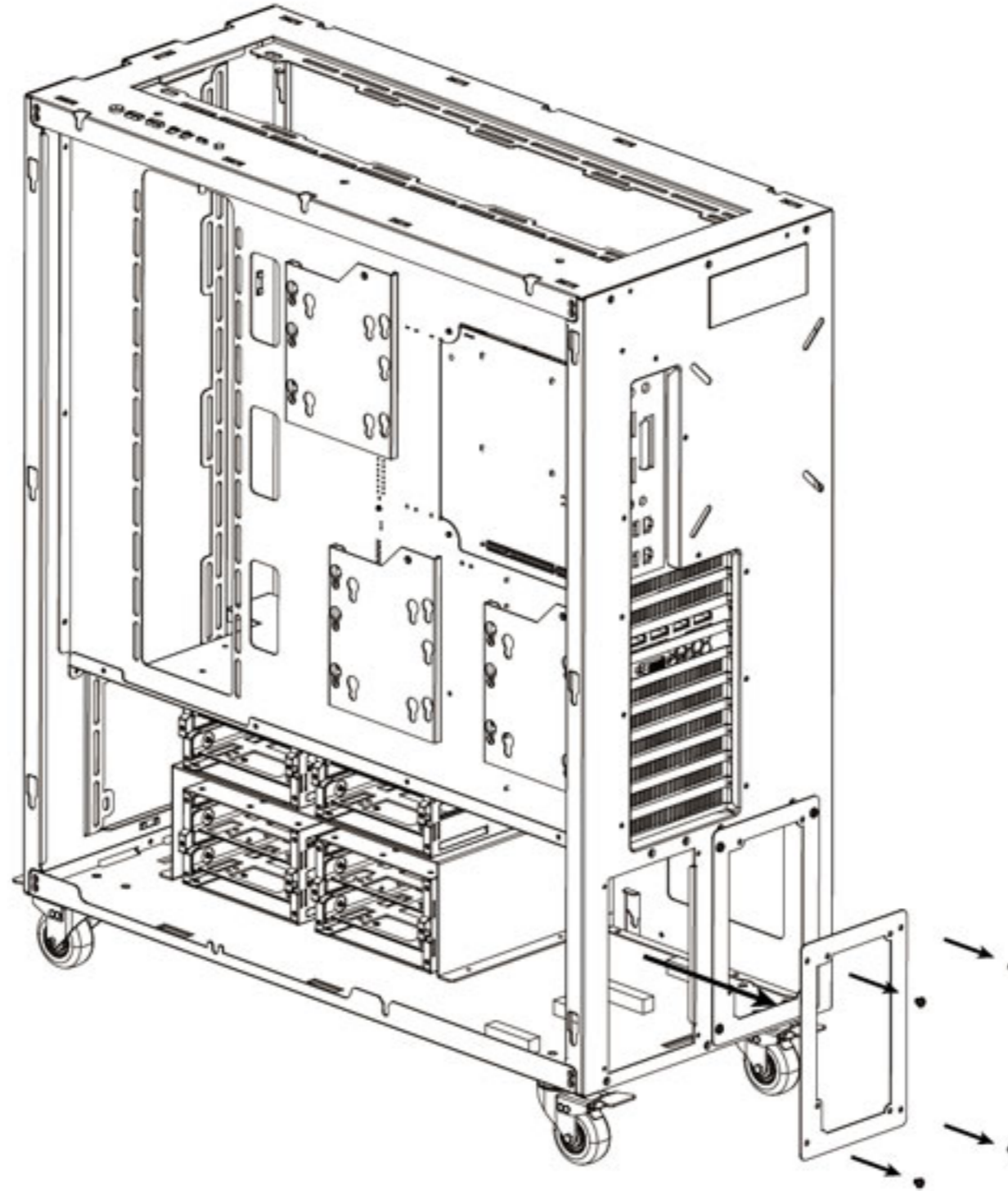

A  x 4

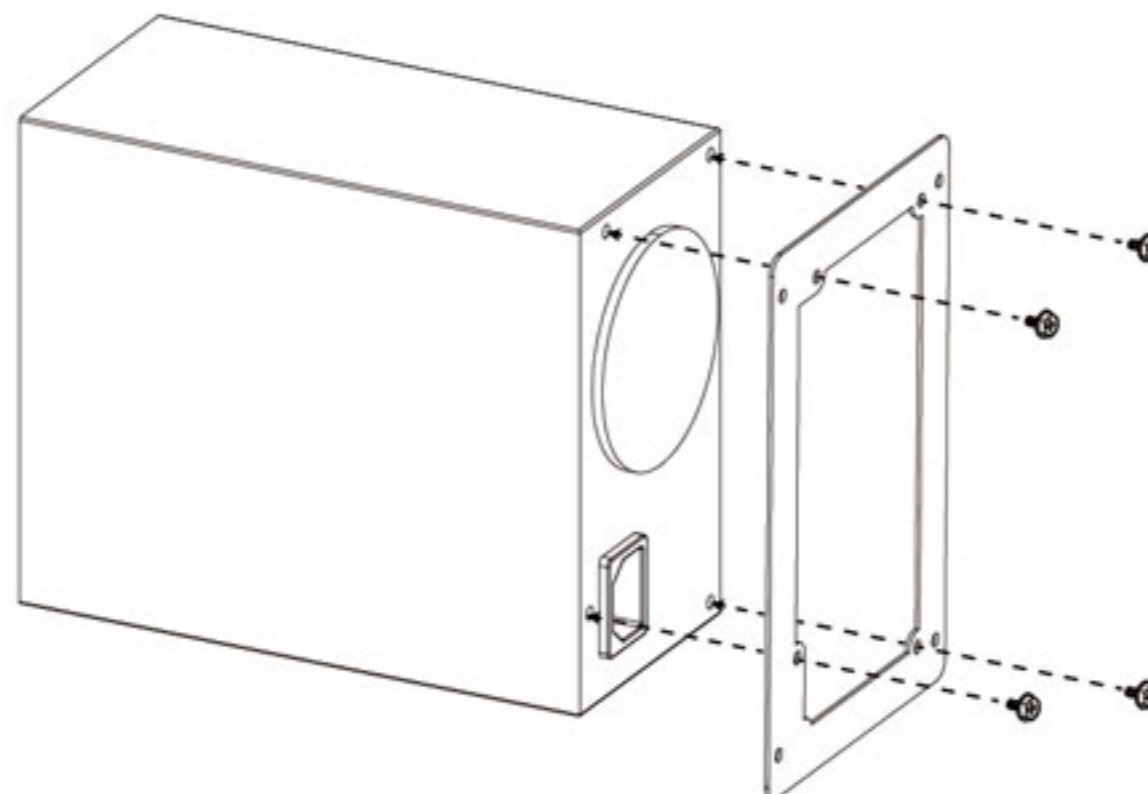

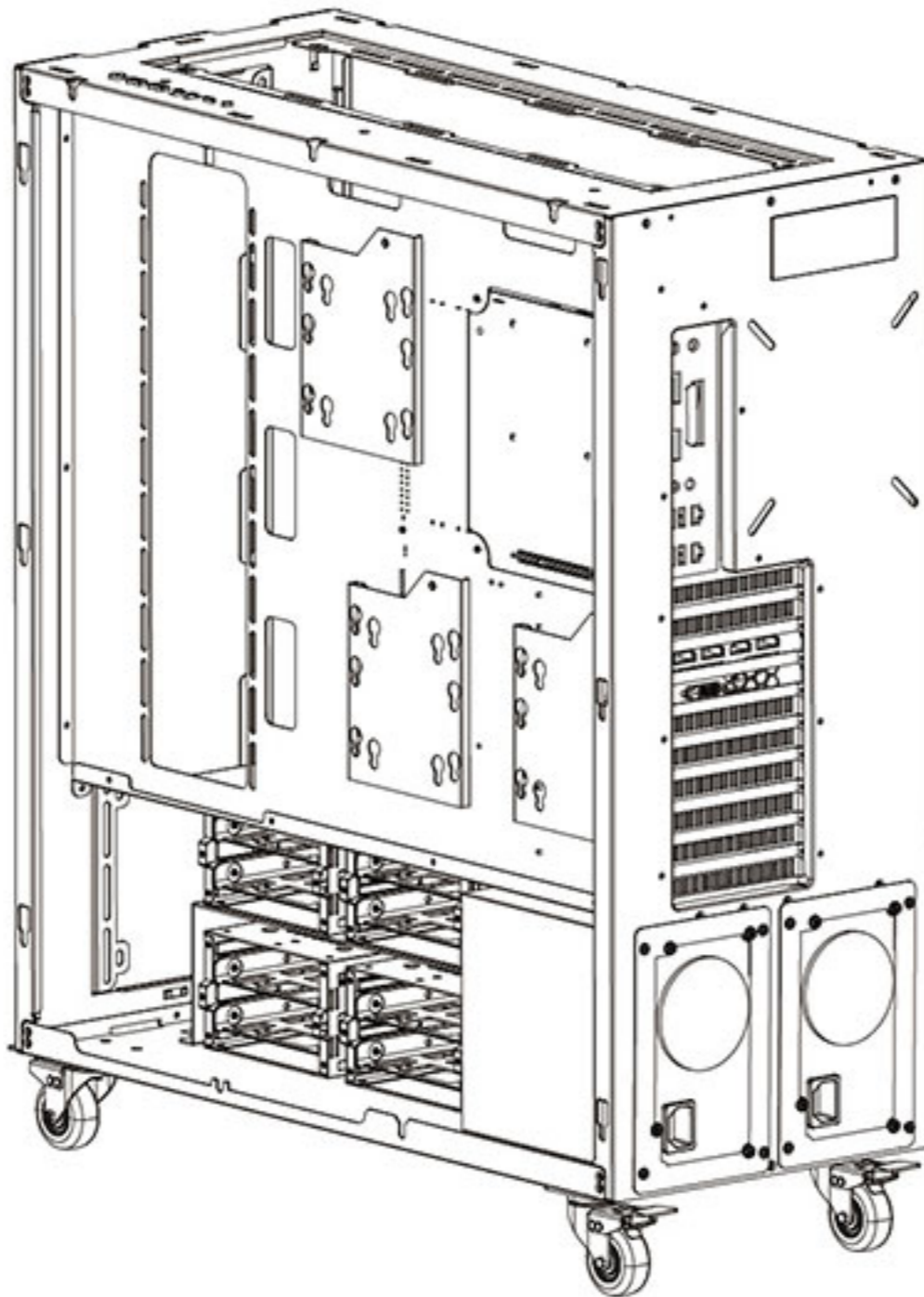
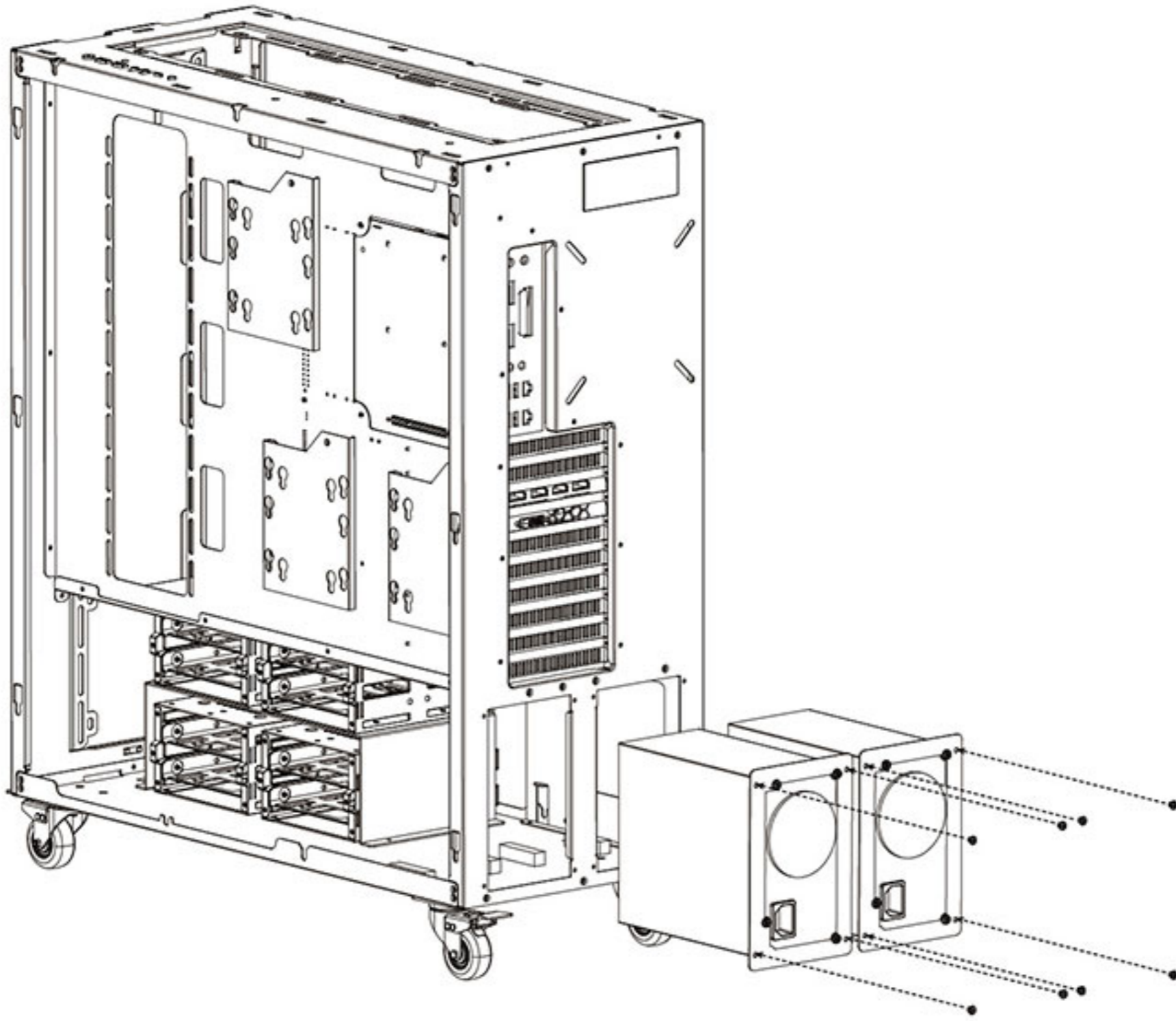

Install the 3.5"/2.5" Drives

安裝3.5"/2.5"硬碟 | 安裝3.5"/2.5"硬盤 | 3.5/2.5ドライブの取り付け | 3.5"/2.5" 드라이브 설치 |
 Installate i drive 3.5"/2.5" | Installer les lecteurs 3.5"/2.5" |
 Установите 3,5/2,5-дюймовые диски | Installation der 3,5-Zoll-/2,5-Zoll-Laufwerke |
 Installera 3,5"/2,5"-enheterna | Zainstaluj napędy 3,5"/2,5" |
 3,5"/2,5" Sürücüleri Takın | Instalar as unidades de 3,5"/2,5" |
 Instalar las unidades de 3,5"/2,5" | Nainstalujte 3,5"/2,5" jednotky

3.5" HDD Drive

C  x 4

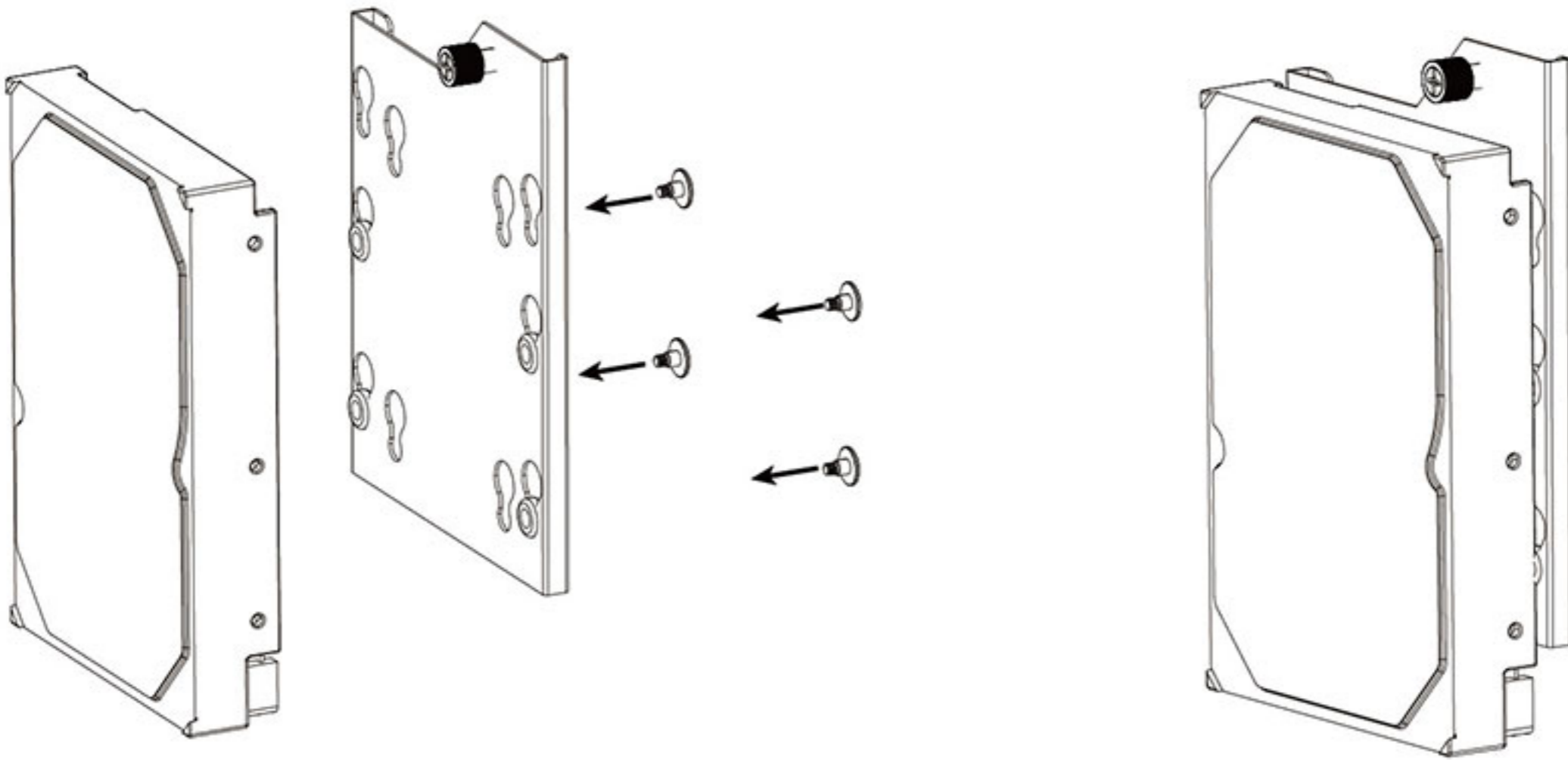

2.5" SSD Drive

D  x 4

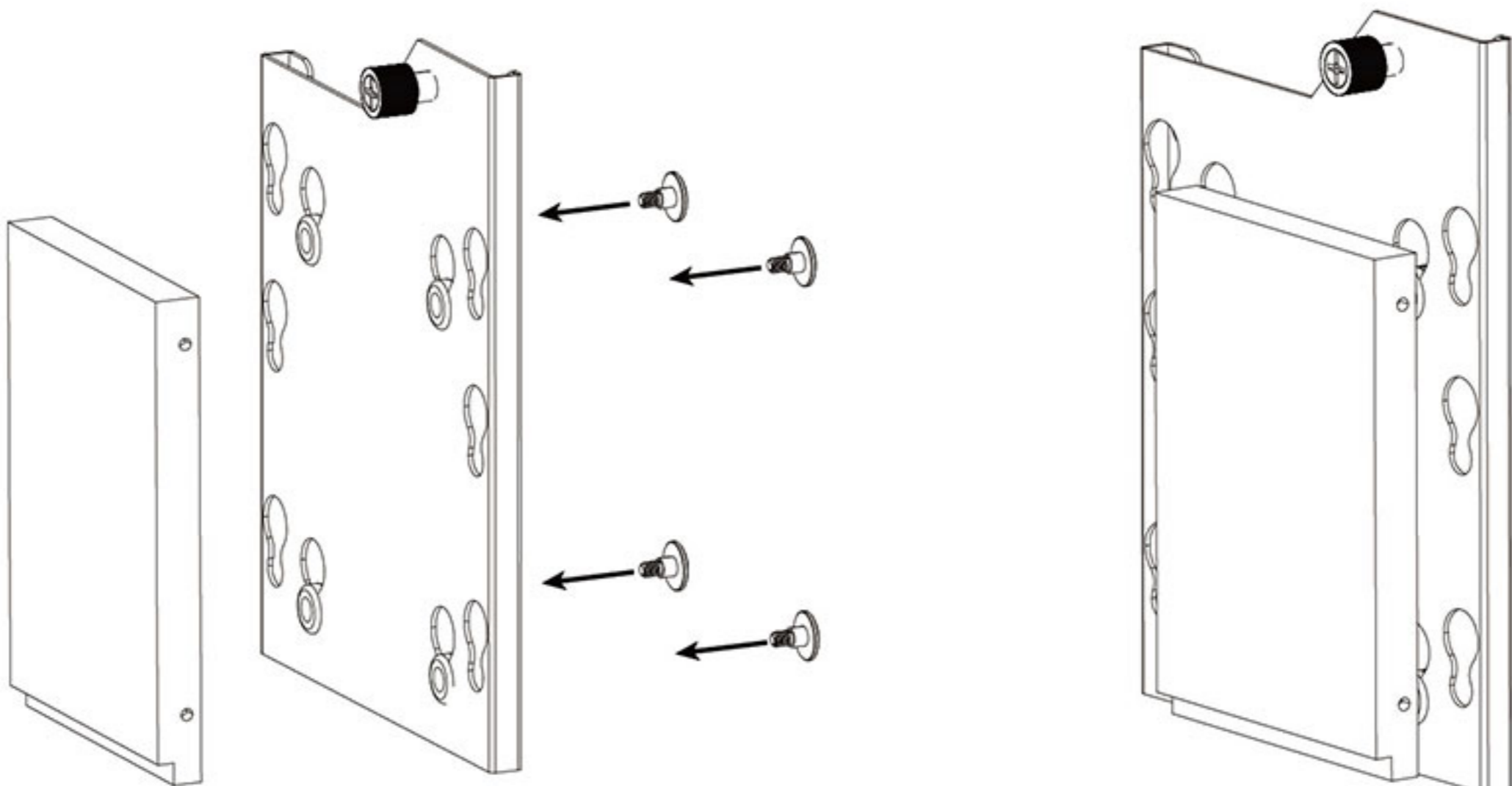

1.

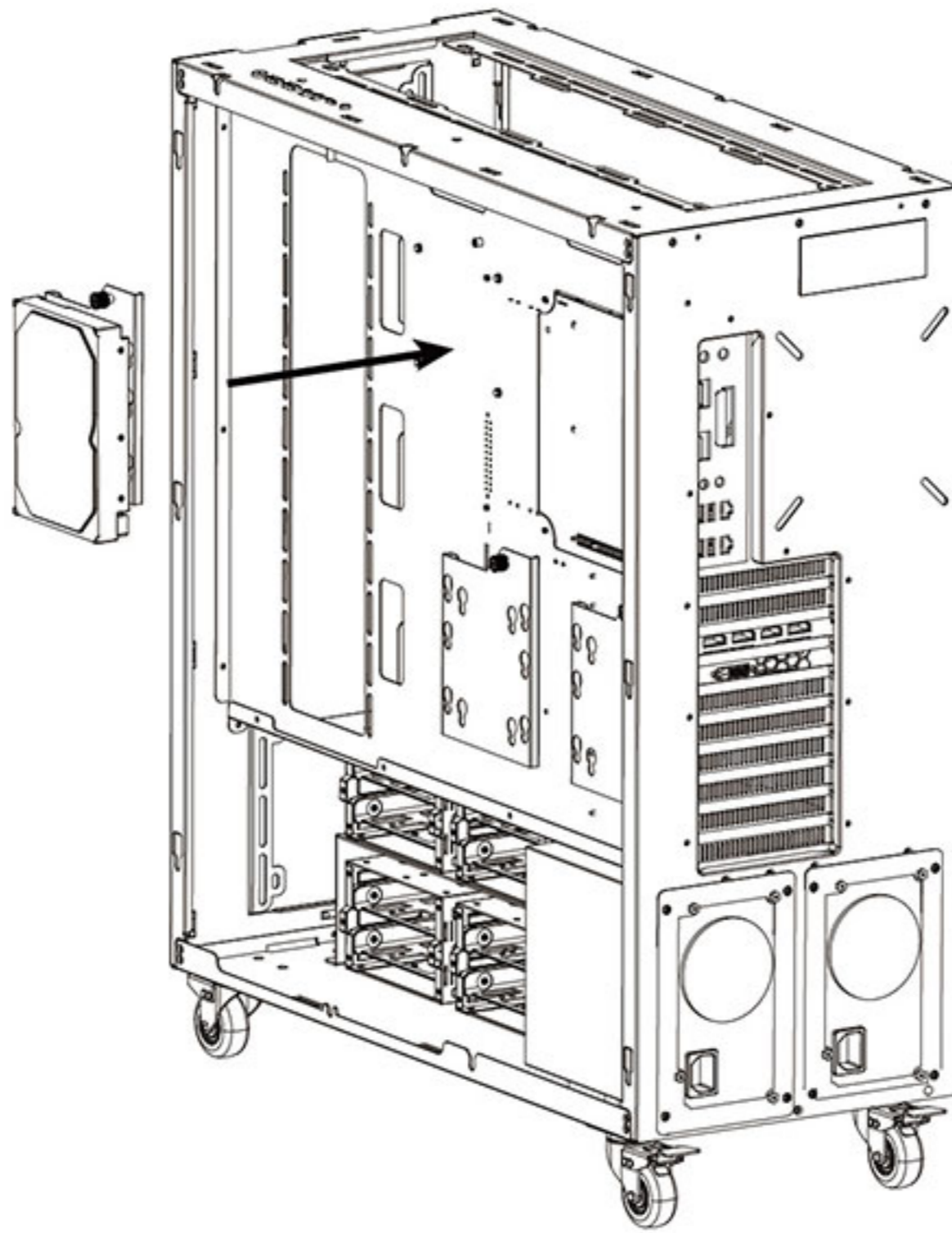

2.

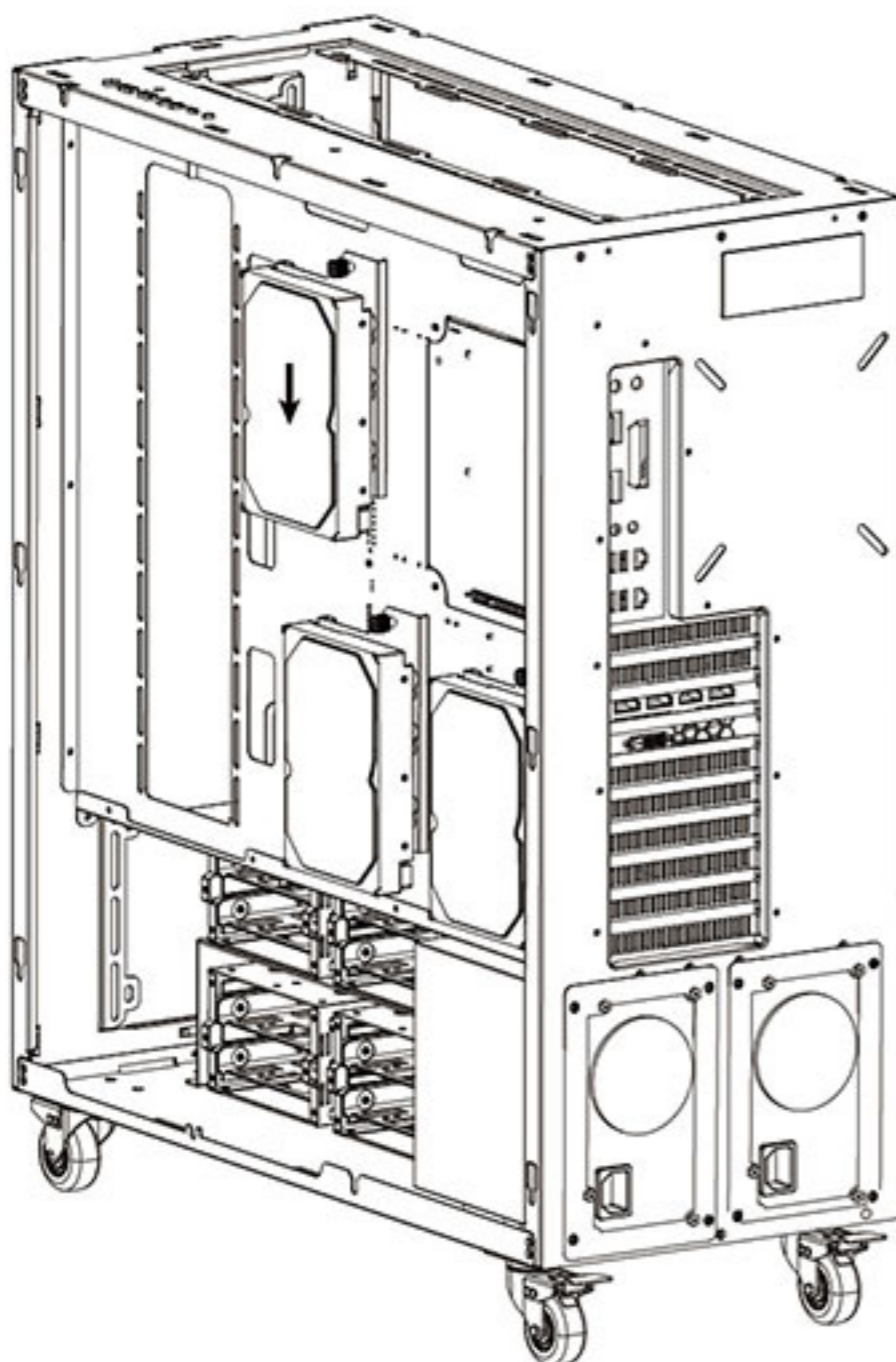

3.

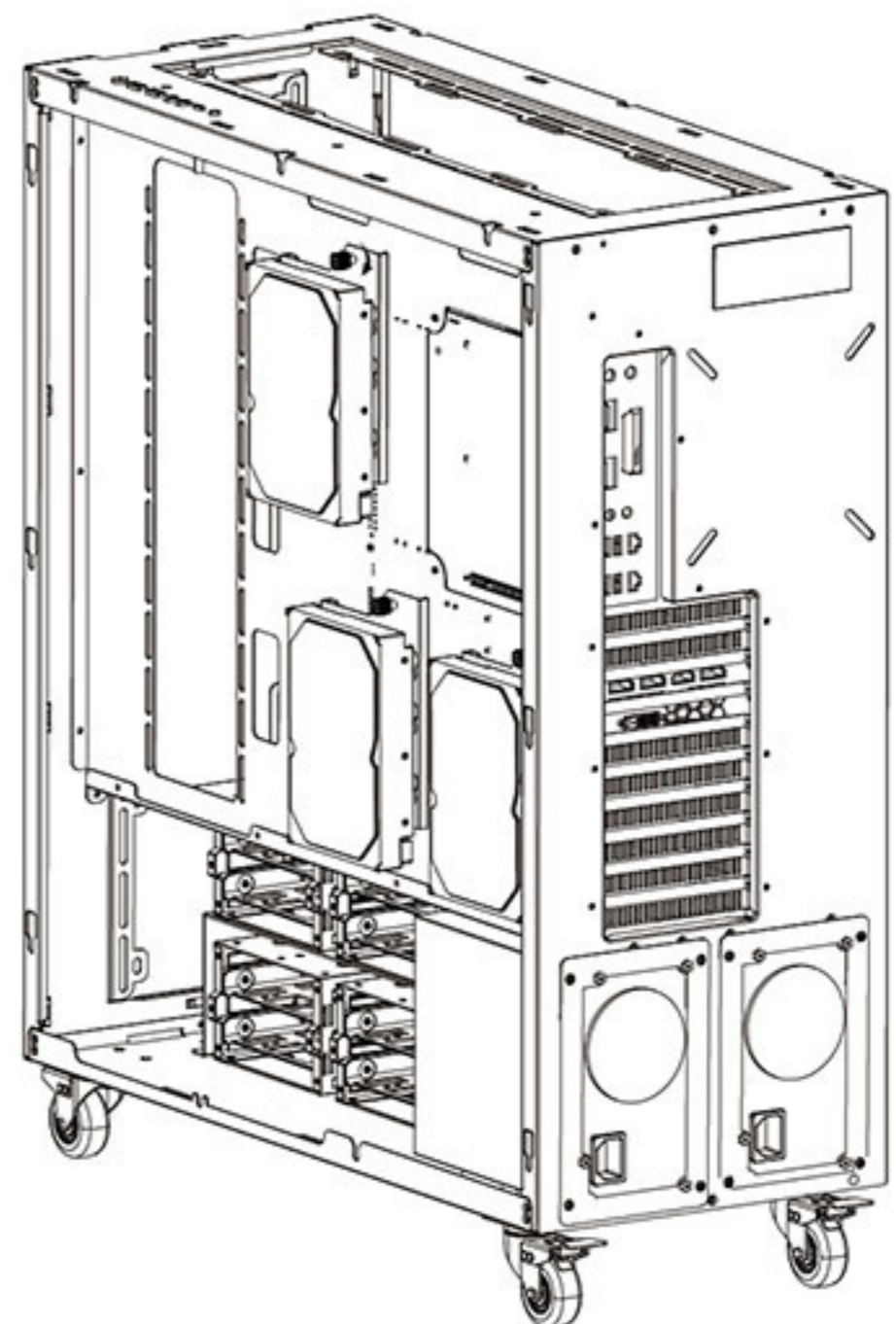

1.

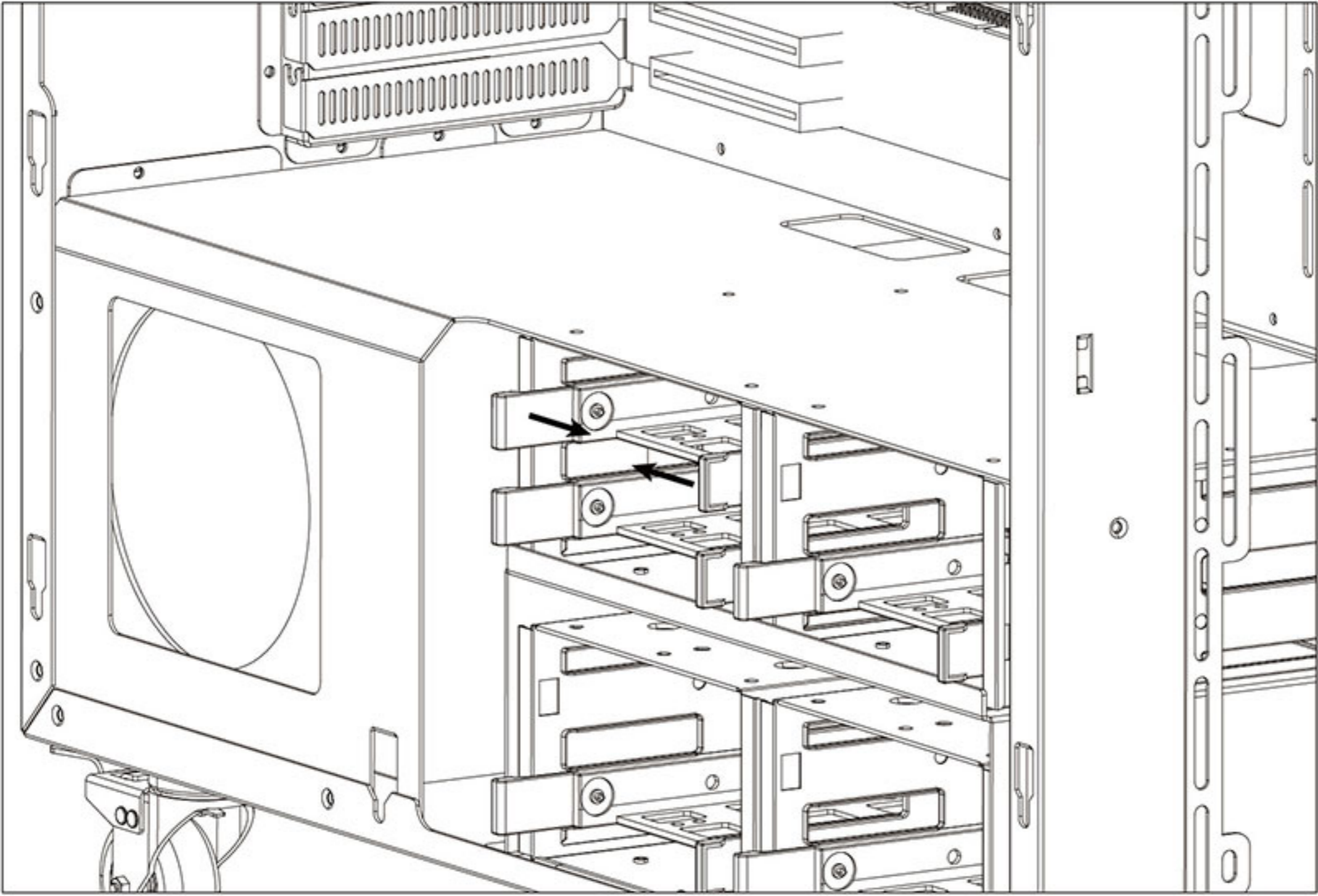

2.

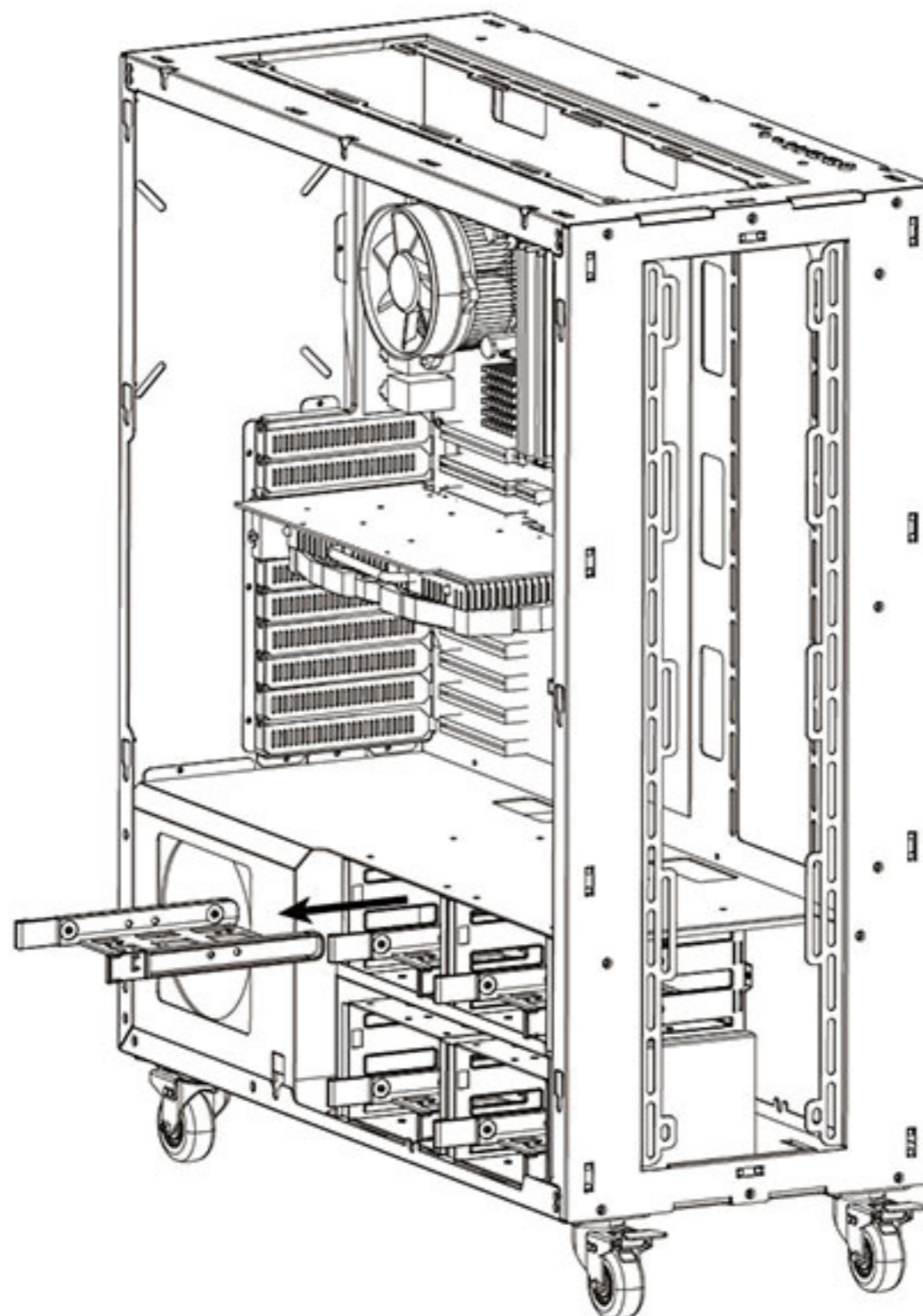

3.5" HDD Drive

E  x 2

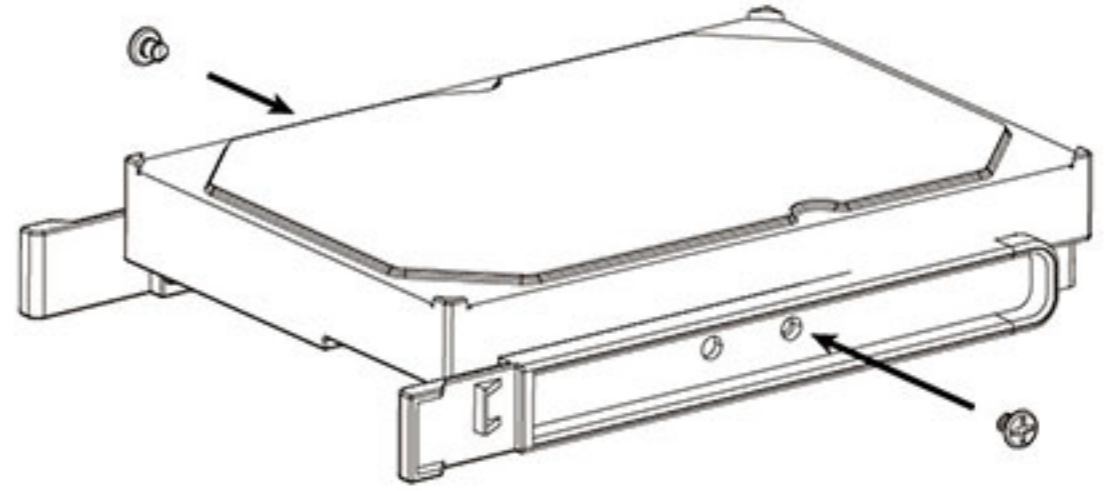
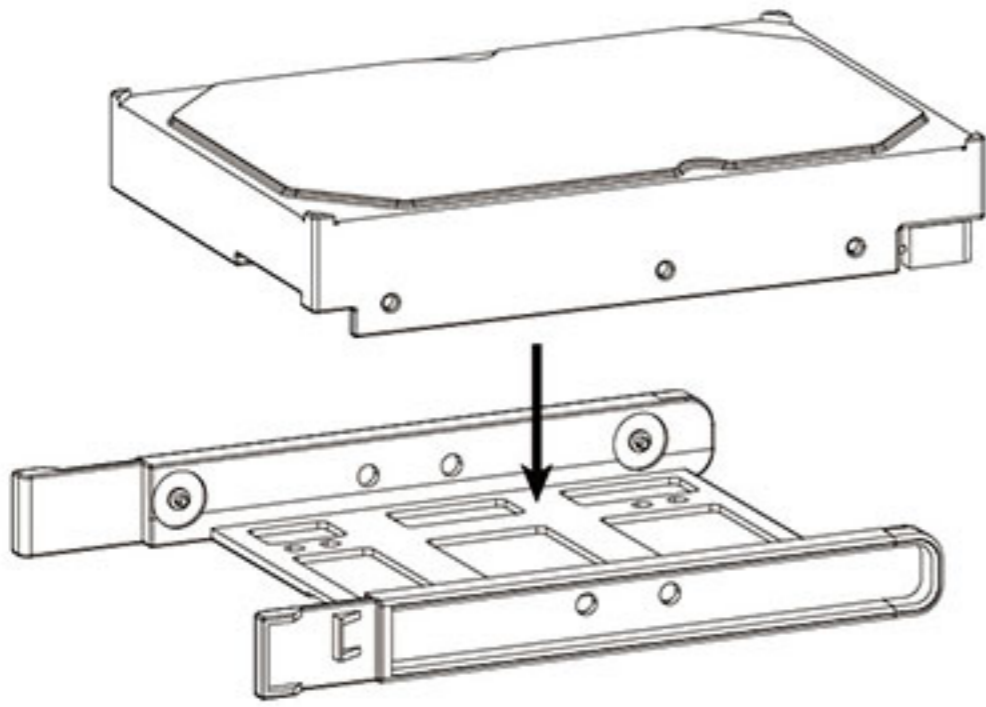

2.5" SSD Drive

B  x 4

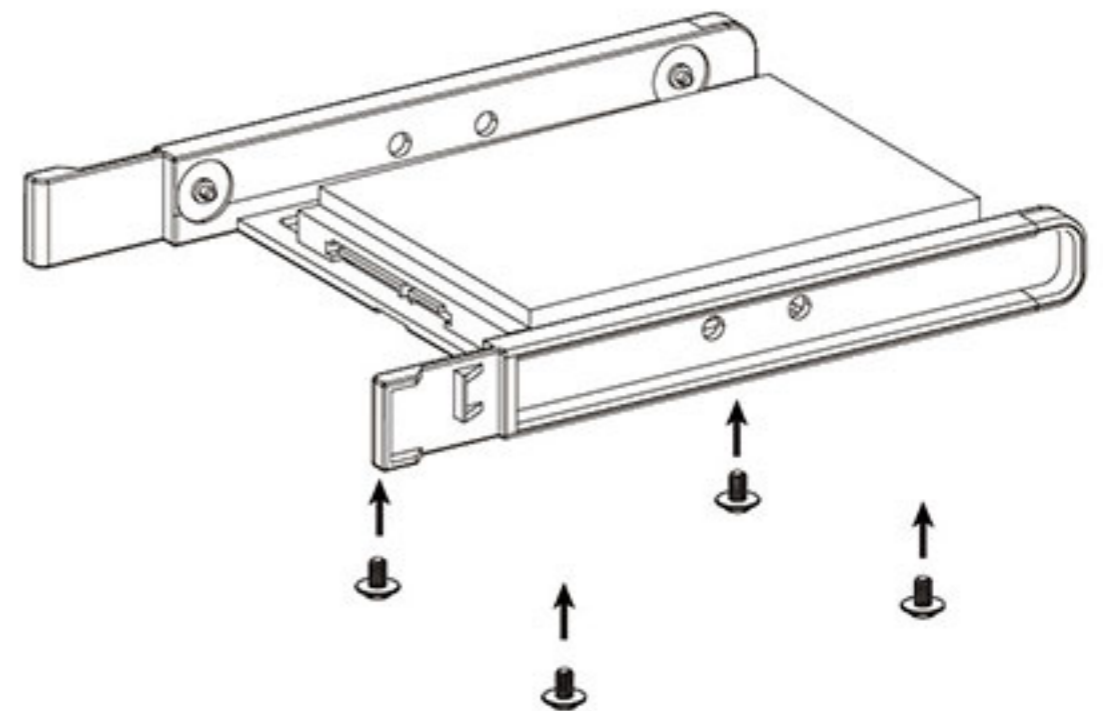
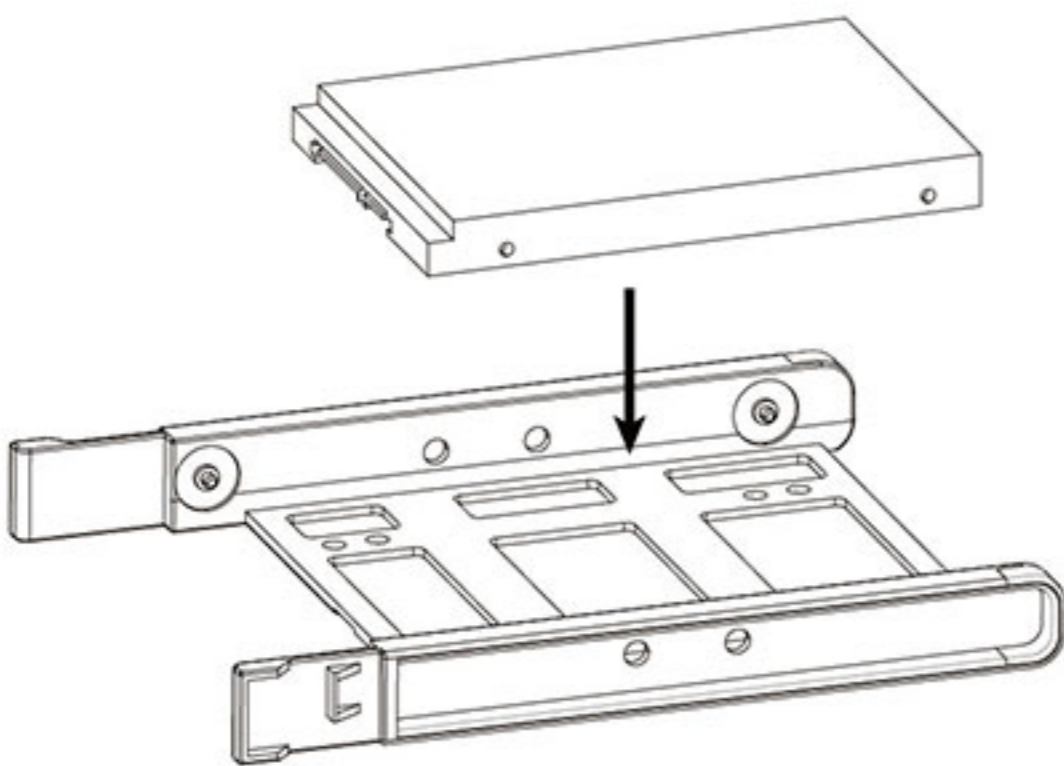

1.

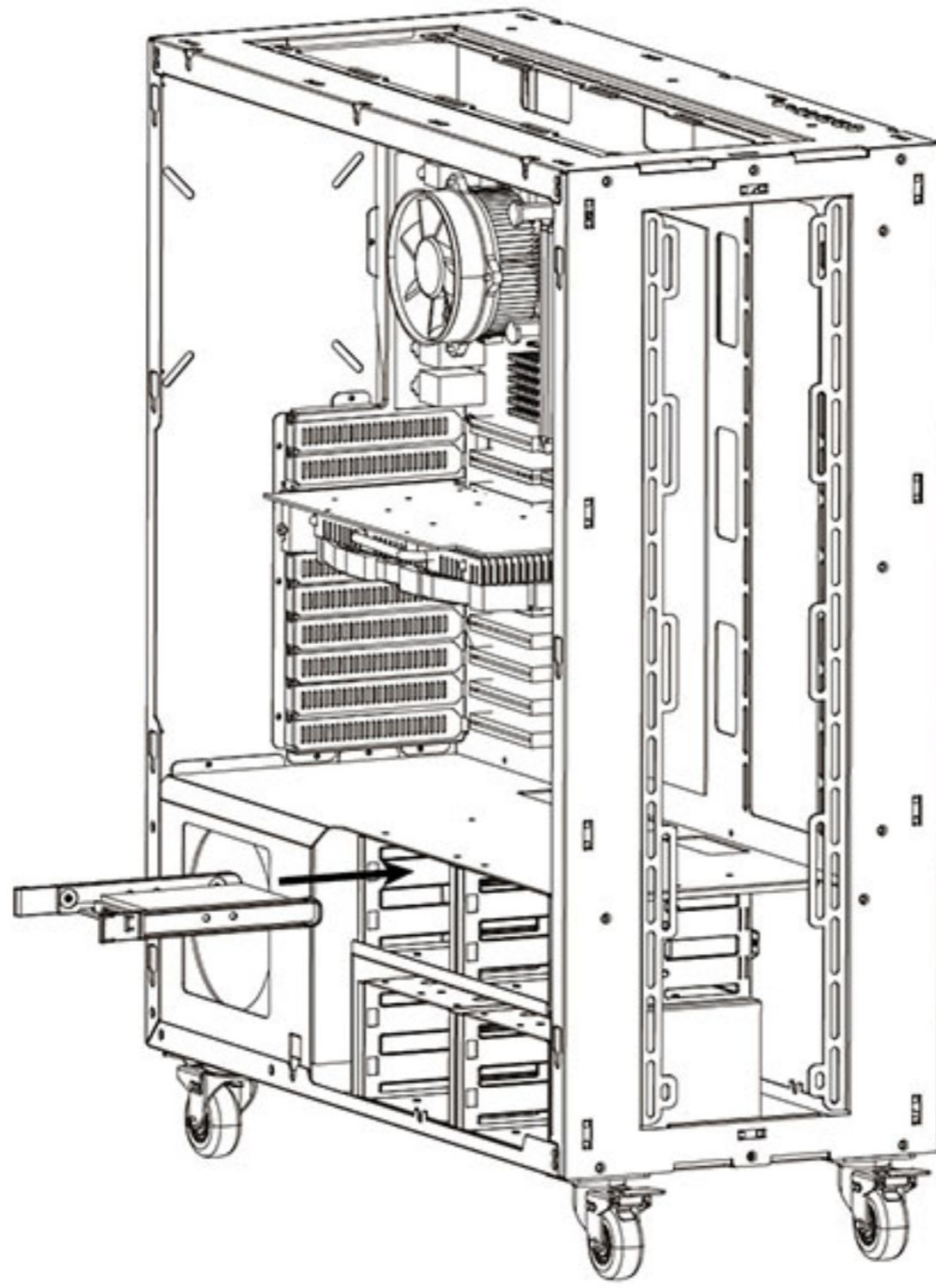

2.

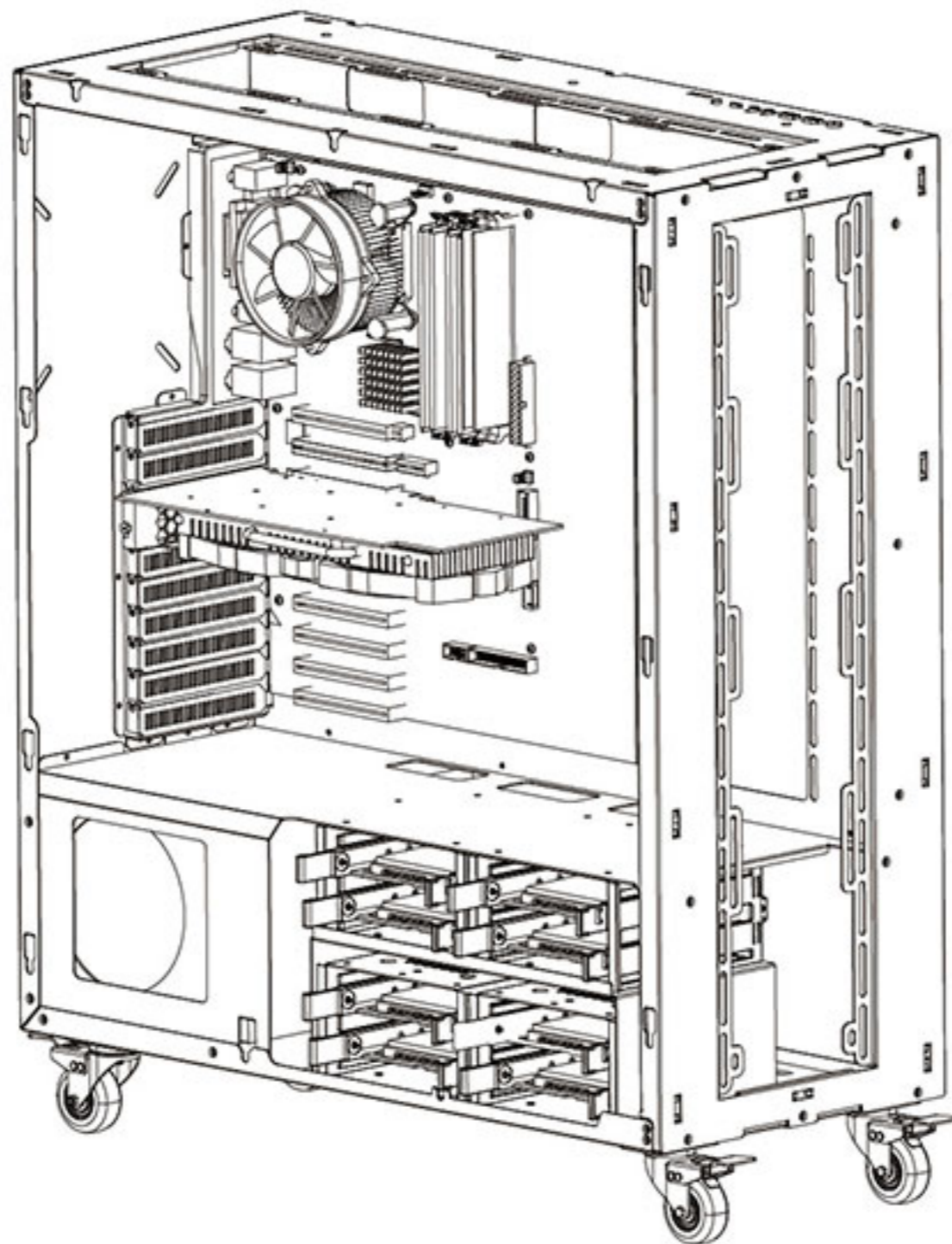

Fan Setup Compatibility

風扇設置相容性 | 風扇設置兼容性 | ファン設定の互換性 | 팬 설치 호환성 |
 Specifiche di installazione per le ventole | Compatibilité de configuration du ventilateur |
 Совместимость устанавливаемого вентилятора |
 Kompatibilität der Lüftereinrichtung | Kompatibilitet för fläktinstallation |
 Zgodność instalacji wentylatora | Fan Kurulumu Uyumluluğu |
 Compatibilidade de ventiladores | Compatibilidad de la configuración del ventilador |
 Kompatibilita nastavení ventilátoru

Top:120mm x 4
 Front:120mm x 4
 Rear:120mm x 1
 Side:120mm x 3

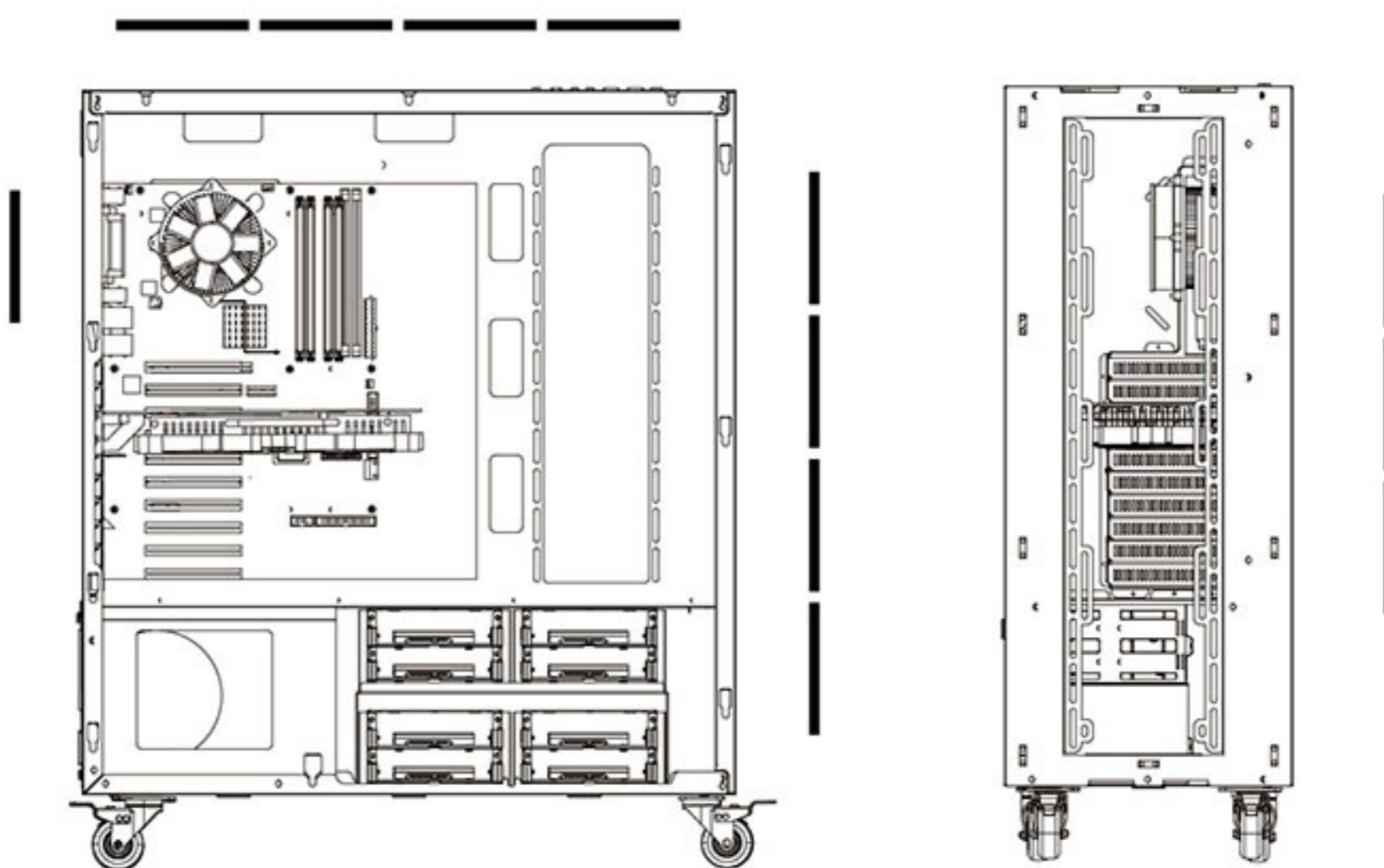

Top:140mm x 3
 Front:140mm x 4
 Rear:140mm x 1

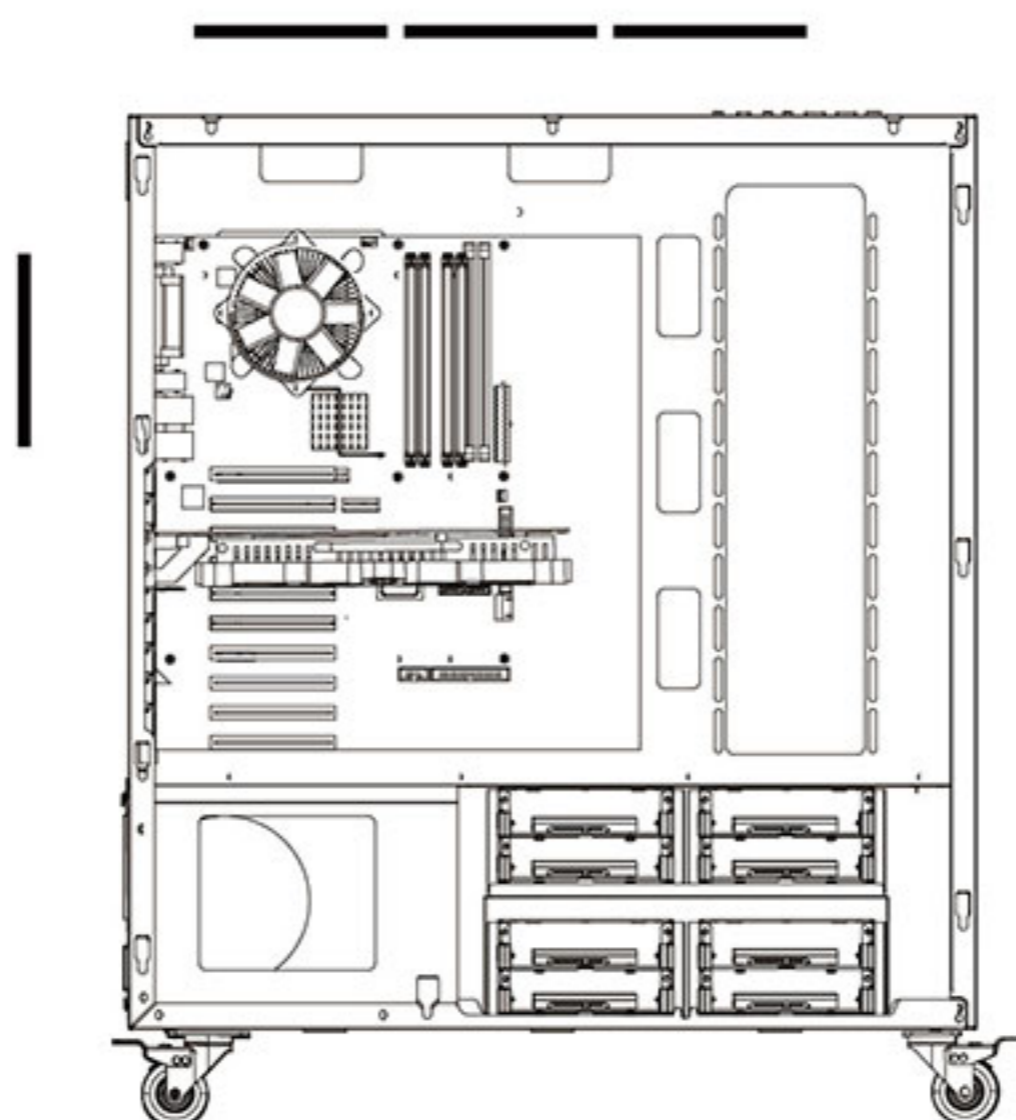

Water-cooling Radiator Options

水冷散熱系統選項 | 水冷散热系统选项 | 水冷式冷却システムのオプション |

수냉식 라디에이터 옵션 | Opzioni per radiatore raffreddamento a liquido |

Options de radiateur à refroidissement par eau |

Варианты радиатора для водяного охлаждения | Optionen der Wasserkühlung |

Alternativ för vattenkylningselement | Opcje instalacji radiatora chłodzonego wodą |

Su Soğutma Radyatörü Seçenekleri | Opções de radiadores de refrigeração a água |

Opciones del radiador de refrigeración por agua |

Možnosti chladiče vodního chlazení

Top:480mm

Front:360mm

Rear:140mm

Side:360mm

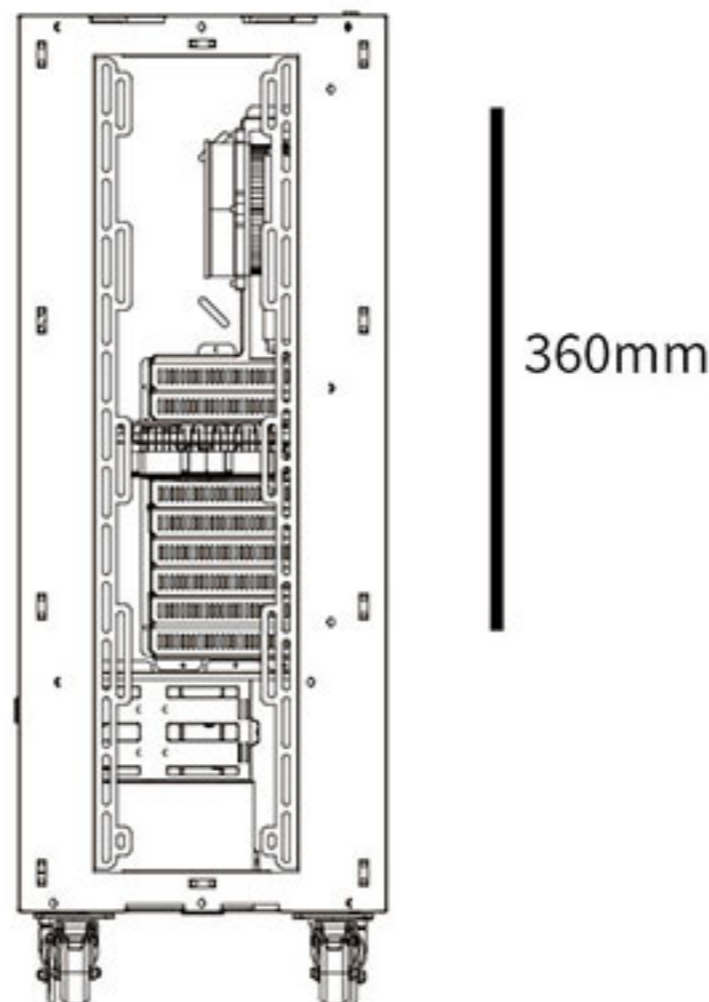
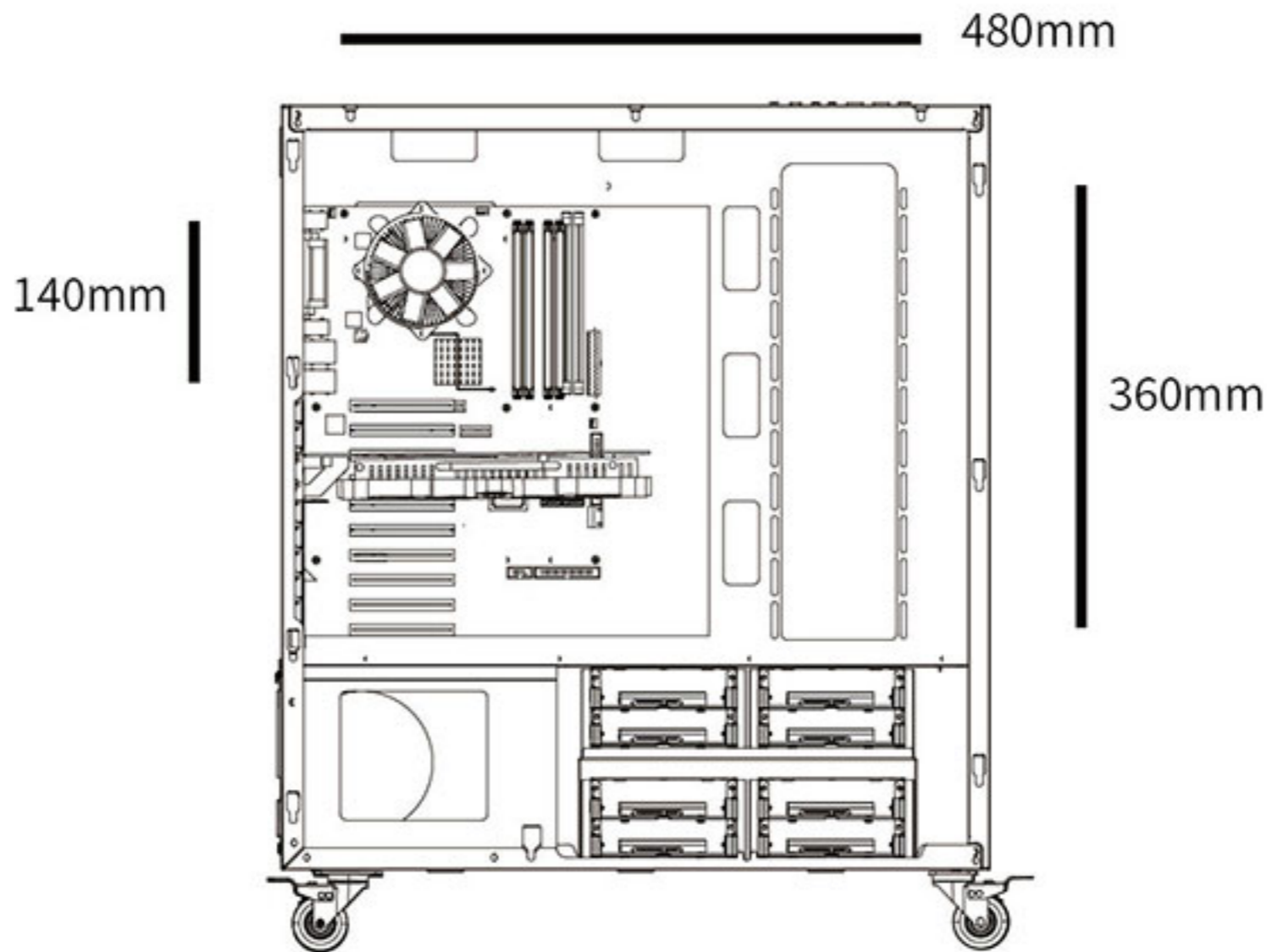

Warranty Information

English (EN)

Abee guarantees that this device is free of defect in material and workmanship, and provides a two-year limited hardware warranty for the device commencing from the date of purchase. Please keep your receipt of proof of purchase. This product is designed for computer usage only. Using this device in any other capacity voids the warranty. If you are not familiar with compute hardware installation, please ask for professional assistance.

The warranty offered covers normal use. Defect or damage that result from improper operation, storage, misuse or abuse, accident or neglect, which are not the fault of abee, are excluded from warranty coverage.

Note: the warranty is voided by removal or alternation of product or parts identification labels.

*In case of conflict between the warranty provided by the country of point of sale and this manual, the warranty of the actual country of point of sale shall be the prevailing document.

*In case of malfunction of electronic components or need of accessories purchase during the warranty period, please return to the original store of purchase.

繁体中文 (ZHT)

Abee保證本設備之材質及功能無瑕疵，並提供本設備二年之硬件有限保修服務，自購買日算起。請把您的收據放在安全之處，以免abee要求您提供本證明。本產品專為計算機設計。一旦將本設備用於其它用途，則保修無效。

若您不熟悉硬件安裝程序，請尋求專家之協助。保修服務僅適用於正常使用下之故障情形。若本公司發現設備毀損之原因為濫用、改造、誤用、疏忽、電壓供應錯誤、空氣及水污染意外和自然災害，則保修無效。

注意：重貼或條形碼遭毀壞而無法辨識保修期限者，則不在此限。

*如果銷售國家所提供的保修與本說明互有衝突時，應以實際銷售國家之保修為準。

*保修期內遇有電子零件故障或配件購買需求，請聯繫原購買商店。

简体中文 (ZHS)

Abee保证本设备之材质及功能无瑕疵,并提供本设备二年之硬件有限保修服务,自购买日算起。请把您的收据放在安全之处,以免abee要求您提供本证明。本产品专为计算机设计。一旦将本设备用于其它用途,则保修无效。若您不熟悉硬件安装程序,请寻求专家之协助。保修服务仅适用于正常使用下之故障情形。若本公司发现设备毁损之原因为滥用、改造、误用、疏忽、电压供应错误、空气及水污染意外和自然灾害,则保修无效。

注意:重贴或条形码遭毁坏而无法辨识保修期限者,则不在此限。

*如果销售国家所提供的保修与本说明互有冲突时,应以实际销售国家之保修为准。

*保修期内遇有电子零件故障或配件购买需求,请联系原购买商店。



电子电气产品有害物质限制使用标识:图中之数字为产品之环保使用限期。仅指电子电气产品中含有的有害物质不致发生外泄或突变,从而对环境造成污染或对人身、财产造成严重损害的期限。

有害物质名称及含量说明标示:

部件名称	有害物质					
	铅 (Pb)	汞 (Hg)	镉 (Cd)	六价铬 (Cr+6)	多溴联苯 (PBB)	多溴二苯醚 (PBDE)
机箱组	○	○	○	○	○	○
面板组	○	○	○	○	○	○
I/O模组	○	○	○	○	○	○
零件包	○	○	○	○	○	○

本表格依据SJ/T11364的规定编制。

○:表示该有害物质在该部件所有均质材料中的含量在GB/T 26572规定的限量要求下。

×:表示该有害物质至少在该部件的某一均质材料的含量超出GB/T 26572规定的限量要求,该部件仍符合欧盟指令2011/65/EU的规范。

备注:此产品标示之环保使用期限,系指在一般正常使用状况下。



abee Intelligent Manufacturing (Dongguan) Co.,Ltd.
Zip Code: 523808, Room 1102, Block 1, CIMC Intelligence Vally,
No.2 Nanbo Road, Songshan Lake District,
Dongguan City, Guangdong Province, P.R.C. China

蜂翼智造(東莞)有限公司

中國廣東省東莞市松山湖高新技術產業開發區南波路2號 中集智谷28棟1102室
(郵地區號:523808)

蜂翼智造(东莞)有限公司

中国广东省东莞市松山湖高新技术产业开发区南波路2号 中集智谷28栋1102室
(邮编:523808)

Website: www.abeepc.com

Email: abee@abeepc.com

TEL: +86-769-23070070